



# Product Specification DataSheet

## SFP-10G-ZR



**RoHS Compliant 10Gb/s SFP+ 1550nm 80km Optical Transceiver**



## PRODUCT FEATURES

- Hot pluggable
- 10Gb/s serial optical interface
- Up to 80km on 9/125um SMF
- Compliant with SFP+ MSA
- SFP MSA package with duplex LC connector
- Digital Diagnostic Monitor Interface
- Very low EMI and excellent ESD protection
- High transmission margin
- +3.3V single power supply
- Below <1.8W power consumption
- SFP mechanical interface
- Wide data-rate range

## APPLICATIONS

- 10G Base-ZR/ZW
- 10G Fiber Channel
- Other optical links

## STANDARD

- SFP+ MSA Compliant
- SFF-8472 reversion 9.5 compliant
- IEEE802.3-2005 compliant
- Telcordia GR-468-CORE compliant
- FCC 47 CFR Part 15, Class B compliant
- FDA 21 CFR 1040.10 and 1040.11, class1 compliant
- RoHS compliant

## PRODUCT DESCRIPTIONS

● TINOUT's SFP-10G-ZR optical transceivers are designed for 10Gb/s serial optical interfaces for data communications with single mode fiber (SMF). The transceiver can support 1.25Gb/s to 11.1Gb/s.

● The transceiver designs are optimized for high performance and cost effective to supply customers the best solutions for datacom and storage applications.



**FUNCTIONAL DIAGRAM**

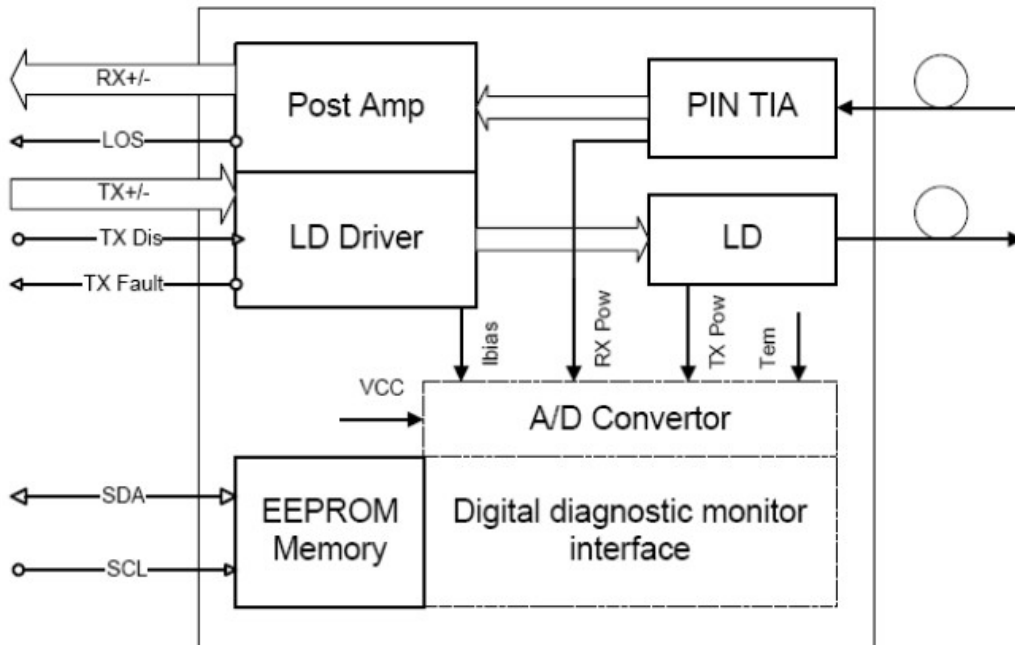

**ABSOLUTE MAXIMUM RATINGS**

Parameter	Symbol	Min.	Max.	Unit	Note
Supply Voltage	Vcc	-0.5	4.0	V	
Storage Temperature		-40	85	°C	
Relative Humidity			85	%	

*Note: Stress in excess of the maximum absolute ratings can cause permanent damage to the module*

**GERERAL OPERATING CHARACTERISTICS**

Parameter	Symbol	Min.	Typ	Max.	Unit	Note
Data Rate	Ethernet		10.3125		Gb/s	
	Fiber Channel		9.953			
Supply Voltage	Vcc	3.13	3.3	3.47	V	
	Vcc				V	
Supply Current	Icc <sub>s</sub>				mA	
	Icc <sub>3</sub>			500	mA	
Operating Case Temp.	Tc	0		70	°C	



## ELECTRICAL INPUT/OUTPUT CHARACTERISTICS

### I Transmitter

Parameter	Symbol	Min.	Typ	Max.	Unit	Note
Diff. input voltage swing		120		820	mVpp	1
Tx Disable input	H	VIH	2.0	Vcc+0.3	V	
	L	VIL	0	0.8		
Tx Fault output	H	VOH	2.0	Vcc+0.3	V	2
	L	VOL	0	0.8		
Input Diff. Impedance	Zin		100		Ω	

### I Receiver

Parameter	Symbol	Min.	Typ	Max.	Unit	Note
Diff. output voltage swing		340	650	800	mVpp	3
Rx LOS Output	H	VOH	2.0	Vcc+0.3	V	2
	L	VOL	0	0.8		

Note 1) TD+/- are internally AC coupled with 100Ω differential termination inside the module.

Note 2) Tx Fault and Rx LOS are open collector outputs, which should be pulled up with 4.7k to 10kΩ resistors on the host board. Pull up voltage between 2.0V and Vcc+0.3V.

Note 3) RD+/- outputs are internally AC coupled, and should be terminated with 100Ω (differential) at the user SERDES.

## OPTICAL CHARACTERISTICS

### I Transmitter (0~70°C@10.3125Gb/s)

Parameter	Symbol	Min.	Typ	Max.	Unit	Note
Operating Wavelength			1550		nm	
Ave. output power (Enabled)	Po	0		4	dBm	1
Extinction Ratio	ER	8.5			dB	1
RMS spectral width	Δλ			1	nm	
Rise/Fall time (20%~80%)	Tr/Tf			50	ps	2
Optical modulation amplitude	OMA	-5.2			dBm	
Dispersion penalty				1	dB	
Output Optical Eye		IEEE 802.3-2005 Compliant				

### I Receiver (0~70°C@10.3125Gb/s)

Parameter	Symbol	Min.	Typ	Max.	Unit	Note
Operating Wavelength		1260		1600	nm	
Sensitivity	Psen			-23	dBm	3
Min. overload	Pimax	-7			dBm	
LOS Assert	Pa	-32			dBm	
LOS De-assert	Pd			-25	dBm	
LOS Hysteresis	Pd-Pa	0.5		4	dB	



Note 1) Measured at 10.3125b/s with PRBS 2<sup>31</sup> – 1 NRZ test pattern.

Note 2) 20%~80%

Note 3) Under the ER worst case, measured at 10.3125 Gb/s with PRBS 2<sup>31</sup> - 1 NRZ test pattern for BER < 1x10<sup>-12</sup>

## SERIAL INTERFACE FOR ID AND DDM

The SFP modules implement the 2-wire serial communication protocol as defined in the SFP MSA.

The serial ID information of the SFP modules and Digital Diagnostic Monitor parameters can be accessed through the I2C interface at address A0h and A2h. The memory is mapped in Table 1. Detailed ID information(A0h) is listed in Table 2. And the DDM specification(A2h) is described in Table 3. For more details of the memory map and byte definitions, please refer to the SFF-8472 (Rev 9.3, Aug. 2002), “Digital Diagnostic Monitoring Interface for Optical Transceivers”.

The DDM parameters have been internally calibrated.

Table 1. Digital Diagnostic Memory Map (Specific Data Field Descriptions)

2 wire address 1010000X ( <b>A0h</b> )		2 wire address 1010001X ( <b>A2h</b> )	
Address	Information	Address	Information
0-95	Serial ID Defined by SFP MSA (96 bytes)	0-55	Alarm and Warning Thresholds (56 bytes)
96-127	Vendor Specific (32 bytes)	56-95	Calibration Constants (40 bytes)
128-255	Reserved,SFF8079 (128 bytes)	96-119	Real Time Diagnostic Interface (24 bytes)
		120-127	Vendor Specific (8 bytes)
		128-247	User Writable EEPROM (120 bytes)
		248-255	Vendor Specific (8 bytes)

## PIN DEFINITIONS AND FUNCTIONS

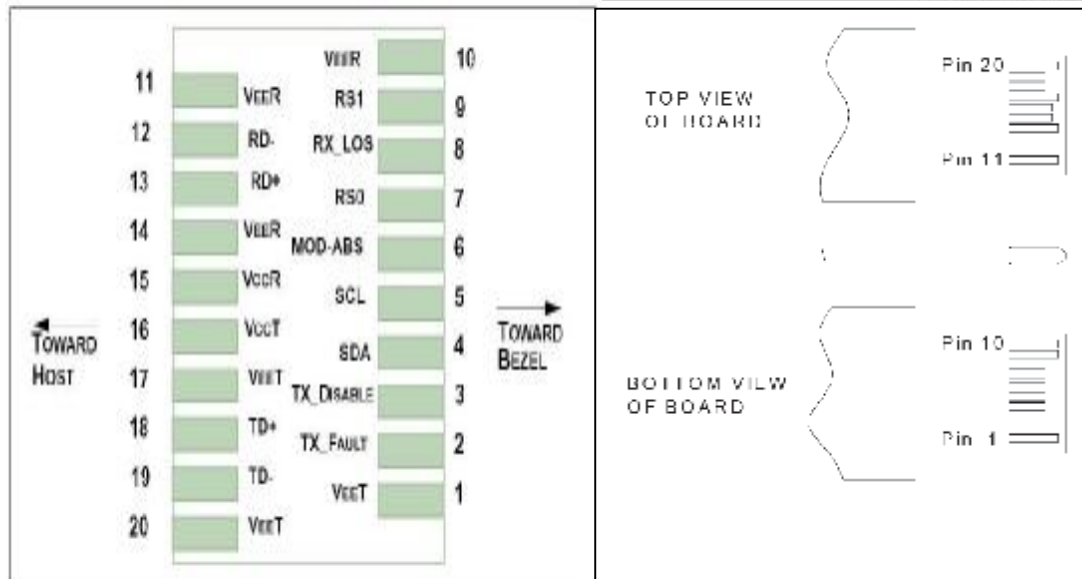

PIN #	Name	Function	Notes
1	VeeT	Module transmitter ground	Note 1
2	Tx Fault	Module transmitter fault	Note 2
3	Tx Disable	Transmitter Disable; Turns off transmitter laser output	Note 3
4	SDL	2 wire serial interface data input/output (SDA)	
5	SCL	2 wire serial interface clock input (SCL)	
6	MOD-ABS	Module Absent, connect to VeeR or VeeT in the module	Note 2
7	RS0	Rate select0, optionally control SFP+ receiver. When high, input data rate >4.5Gb/s; when low, input data rate <=4.5Gb/s	
8	LOS	Receiver Loss of Signal Indication	Note 4
9	RS1	Rate select0, optionally control SFP+ transmitter. When high, input data rate >4.5Gb/s; when low, input data rate <=4.5Gb/s	
10	VeeR	Module receiver ground	Note 1
11	VeeR	Module receiver ground	Note 1
12	RD-	Receiver inverted data out put	
13	RD+	Receiver non-inverted data out put	
14	VeeR	Module receiver ground	Note 1
15	VccR	Module receiver 3.3V supply	
16	VccT	Module transmitter 3.3V supply	
17	VeeT	Module transmitter ground	Note 1
18	TD+	Transmitter inverted data out put	
19	TD-	Transmitter non-inverted data out put	
20	VeeT	Module transmitter ground	Note 1

- Note 1) The module ground pins shall be isolated from the module case.
- Note 2) This pin is an open collector/drain output pin and shall be pulled up with 4.7K-10Kohms to Host\_Vcc on the host board.
- Note 3) This pin shall be pulled up with 4.7K-10Kohms to VccT in the module.
- Note 4) This pin is an open collector/drain output pin and shall be pulled up with 4.7K-10Kohms to Host\_Vcc on the host board. In FC designated as RX\_LOS, inSONET designated as LOS, and in Ethernet designated at Signal Detect.

### TYPICAL INTERFACE CIRCUIT

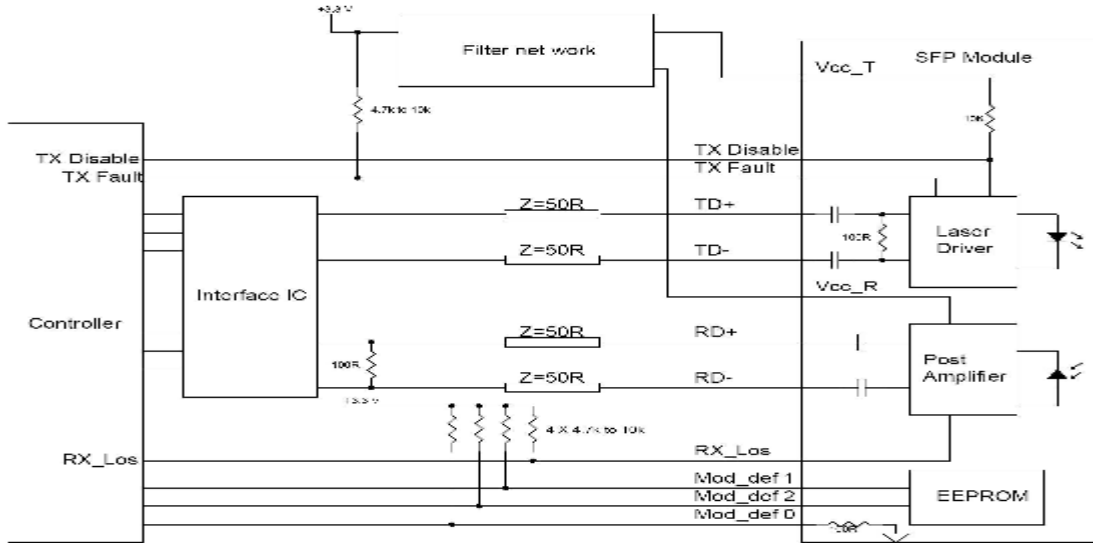

### Recommended power supply filter

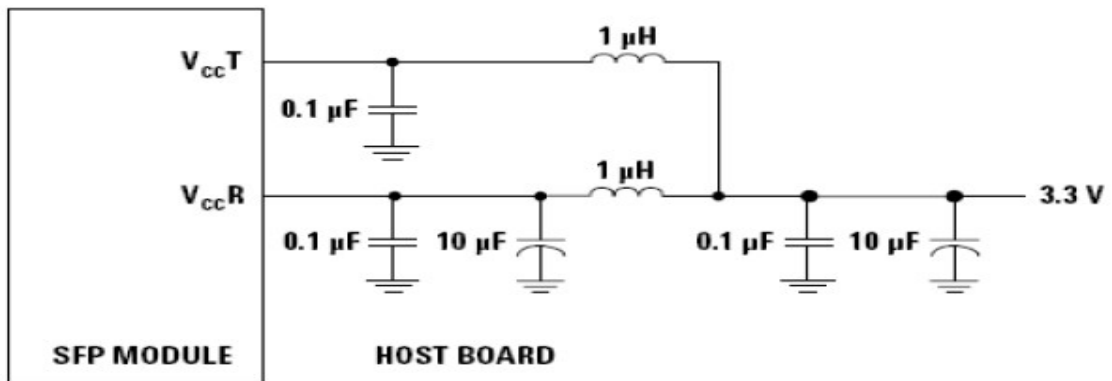

*Note: Inductors with DC resistance of less than 1Ω should be used in order to maintain the required voltage at the SFP input pin with 3.3V supply voltage. When the recommended supply filtering network is used, hot plugging of the SFP transceiver module will result in an inrush current of no more than 30 mA greater than the steady state value*



## ORDERING INFORMATION

Part Number	Description
SFP-10G-SR	SFP+ PLUS,10.3125Gbps, 850nm, 300M, 0~70°C, with DDM
SFP-10G-LR	SFP+ PLUS,10.3125Gbps,1310nm,10KM,0~70°C, with DDM
SFP-10G-LRS	SFP+ PLUS,10.3125Gbps,1310nm,10KM,for SDH,0~70°C, with DDM
SFP-10G-ER	SFP+ PLUS,10.3125Gbps,1550nm,40KM,0~70°C, with DDM
SFP-10G-ZR	SFP+ PLUS,10.3125Gbps,1550nm,80KM,0~70°C, with DDM

## CONTACT INFORMATION

### Europe

contact person: SFP Expert  
phone: 0086-18955924524  
Email: [croft@tinout.com](mailto:croft@tinout.com)

### North America & Latin America

contact person: Daniel  
phone: 0086-18505598810  
Email: [daniel@tinout.com](mailto:daniel@tinout.com)

