

Features:

- F Single Mode bi-directional Transmission
- F SFP Multi-source Package with LC Receptacle
- F Up to 155Mb/s Data Links
- F Hot-Pluggable Capability
- F Single +3.3V Power Supply
- F Isolation > 30dB, Cross Talk < -45dB
- F Compliant with Specifications for IEEE802.3Z
- F Compliant with Bellcore TA-NWT-000983
- F Eye Safety Designed to Meet Laser Class1, Compliant with IEC60825-1

Applications:

- F Fast Ethernet
- F SDH/SONET
- F WDM Application

Specification:

I Electrical and Optical Characteristics: (Condition: T_a=T_{OP})

Parameter	Symbol	Min.	Typical	Max.	Unit
Transmitter Differential Input Voltage	+/-TX_DAT	200		2400	mV p-p
Supply Current	I _{CC}		130	180	mA
Tx_Disable Input Voltage – Low	V _{IL}	0		0.8	V
Tx_Disable Input Voltage – High	V _{IH}	2.0		V _{cc}	V
Tx_Fault Output Voltage – Low	V _{OL}	0		0.8	V
Tx_Fault Output Voltage – High	V _{OH}	2.0		V _{cc}	V
Receiver Differential Output Voltage	+/-RX_DAT	600		1400	mV p-p
Rx_LOS Output Voltage- Low	V _{OL}	0		0.8	V
Rx_LOS Output Voltage- High	V _{OH}	2.0		V _{cc}	V

Transmitter (PTP4232-3L):

Parameter	Symbol	Min.	Typical	Max.	Unit
Data Rate	B	-	155	-	Mb/s
Centre Wavelength	λ _c	1290	1310	1330	nm
Output Spectral Width	Δλ (RMS)	-	-	4	nm
Average Output Power	P _o	-13	-	-6	dBm
Extinction Ratio	EXT	10	-	-	dB
Data Input Voltage-High	V _{IHS}	V _{cc} -1.16	-	V _{cc} -0.89	V
Data Input Voltage -Low	V _{ILS}	V _{cc} -1.82	-	V _{cc} -1.48	V
Supply Current	I _{CC}	-	90	150	mA
Output Optical Eye	Compliant with IEEE802.3Z				

Receiver (PTP4232-3L):

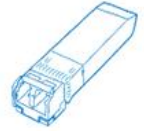

Parameter	Symbol	Min.	Typical	Max.	Unit
Receive Sensitivity	P_{min}	-	-	-33	dBm
Maximum Input Power	P_{MAX}	-3	-	-	dBm
Signal Detection-Asserted	SD_{HIGH}	-	-	-34	dBm
Signal Detection-Deserted	SD_{LOW}	-44	-	-	dBm
Hysteresis	-	-	3.0	-	dBm
Output High Voltage	V_{OH}	$V_{cc}-1.03$	-	$V_{cc}-0.89$	V
Output Low Voltage	V_{OL}	$V_{cc}-1.82$	-	$V_{cc}-1.63$	V
Operating Wavelength	λ_c	1480	1550	1580	nm
Supply Current	I_{CC}	-	80	110	mA

Transmitter (PTP4252-3L):

Parameter	Symbol	Min.	Typical	Max.	Unit
Data Rate	B	-	155	-	Mb/s
Centre Wavelength	λ_c	1480	1550	1580	nm
Output Spectral Width	$\Delta \lambda$	-	-	1	nm
Average Output Power	P_o	-13	-	-6	dBm
Extinction Ratio	EXT	10	-	-	dB
Data Input Voltage-High	V_{IHS}	$V_{cc}-1.16$	-	$V_{cc}-0.89$	V
Data Input Voltage -Low	V_{ILS}	$V_{cc}-1.82$	-	$V_{cc}-1.48$	V
Supply Current	I_{CC}	-	90	150	mA
Output Optical Eye	Compliant with IEEE802.3Z				

Receiver (PTP4252-3L):

Parameter	Symbol	Min.	Typical	Max.	Unit
Receive Sensitivity	P_{min}	-	-	-33	dBm
Maximum Input Power	P_{MAX}	-3	-	-	dBm
Signal Detection-Asserted	SD_{HIGH}	-	-	-34	dBm
Signal Detection-Deserted	SD_{LOW}	-44	-	-	dBm
Hysteresis	-	-	3.0	-	dBm
Output High Voltage	V_{OH}	$V_{cc}-1.03$	-	$V_{cc}-0.89$	V
Output Low Voltage	V_{OL}	$V_{cc}-1.82$	-	$V_{cc}-1.63$	V
Operating Wavelength	λ_c	1260	1310	1360	nm
Supply Current	I_{CC}	-	80	110	mA

I Absolute Maximum Ratings: ($T_C=25^\circ C$)

Parameter	Symbol	Min.	Max.	Unit
Storage Temperature	T_{ST}	-40	+85	$^\circ C$
Operating Temperature	T_{IP}	0	+70	$^\circ C$

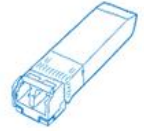

Input Voltage	T_{CC}	0	+5	V
---------------	----------	---	----	---

I Recommended Operating Environment:

Parameter	Symbol	Min.	Typical	Max.	Unit
Supply Voltage	V_{CC}	+3.0	+3.3	+3.6	V
Operating Temperature	T_{OP}	0	-	+70	°C

I Timing Characteristics:

Parameter	Symbol	Min.	Typical	Max.	Unit
TX_DISABLE Assert Time	t_{off}		3	10	usec
TX_DISABLE Negate Time	t_{on}		0.5	1	msec
Time to Initialize Include Reset of TX_FAULT	t_{int}		30	300	msec
TX_FAULT from Fault to Assertion	t_{fault}		20	100	usec
TX_DISBEL Time to Start Reset	t_{reset}	10			usec
Receiver Loss of Signal Assert Time (Off to On)	T_{A,RX_LOS}			100	usec
Receiver Loss of Signal Assert Time (On to Off)	T_{d,RX_LOS}			100	usec

I Serial ID Memory Contents:

Data Address	Length (Byte)	Name of Length	Description and Contents
Base ID Fields			
0	1	Identifier	Type of Serial transceiver (03h=SFP)
1	1	Reserved	Extended identifier of type serial transceiver (04h)
2	1	Connector	Code of optical connector type (07=LC)
3-10	8	Transceiver	Gigabit Ethernet 1000Base-SX & Fiber Channel
11	1	Encoding	8B10B (01h)
12	1	BR,Nominal	Nominal baud rate, unit of 100Mbps
13-14	2	Reserved	(0000h)
15	1	Length(9um)	Link length supported for 9/125um fiber, units of 100m
16	1	Length(50um)	Link length supported for 50/125um fiber, units of 10m
17	1	Length(62.5um)	Link length supported for 62.5/125um fiber, units of 10m
18	1	Length(Copper)	Link length supported for copper, units of meters
19	1	Reserved	
20-35	16	Vendor Name	SFP vendor name: TINOUT
36	1	Reserved	
37-39	3	Vendor OUI	SFP transceiver vendor OUI ID
40-55	16	Vendor PN	Part Number: "PTP4XXX-3L" (ASCII)
56-59	4	Vendor rev	Revision level for part number
60-62	3	Reserved	
63	1	CCID	Least significant byte of sum of data in address 0-62
Extended ID Fields			
64-65	2	Option	Indicates which optical SFP signals are implemented



			(001Ah = LOS, TX_FAULT, TX_DISABLE all supported)
66	1	BR, max	Upper bit rate margin, units of %
67	1	BR, min	Lower bit rate margin, units of %
68-83	16	Vendor SN	Serial number (ASCII)
84-91	8	Date code	TINOUT's Manufacturing date code
92-94	3	Reserved	
95	1	CCEX	Check code for the extended ID Fields (addresses 64 to 94)
Vendor Specific ID Fields			
96-127	32	Readable	TINOUT specific date, read only

Block Diagram of Transceiver:

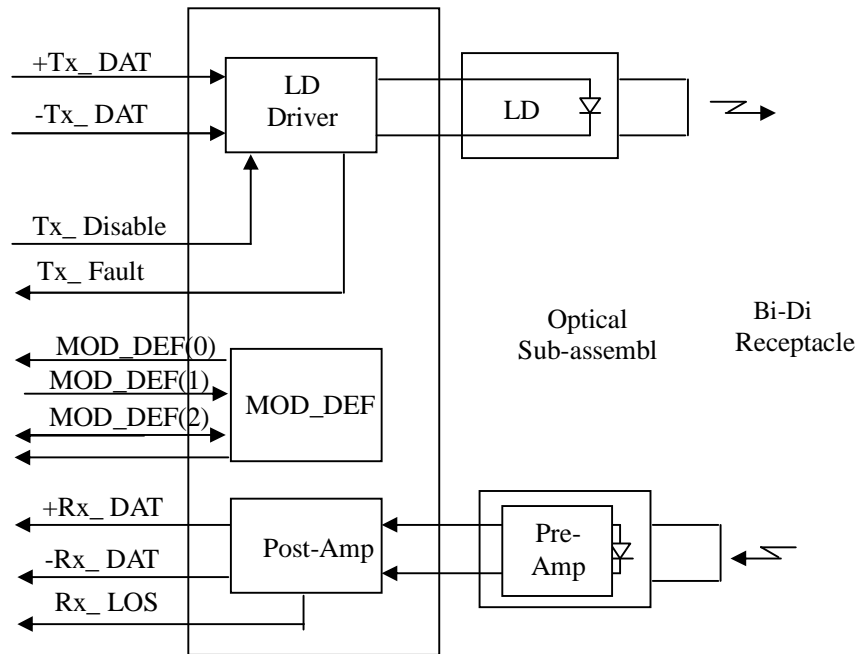

Pin Assignment:

[SFP 155Mb/s Opt](#)
[Hot Pluggable, 1310/1](#)

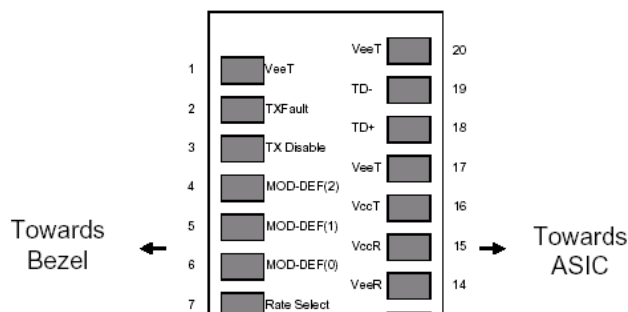

[PTP4252-3L\)](#)

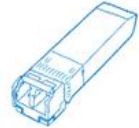

Pin out of Connector Block on Host Board

Pin Description:

Pin	Symbol	Name/Description	Ref.
1	V _{EET}	Transmitter Ground (Common with Receiver Ground)	1
2	T _{FAULT}	Transmitter Fault. Not supported.	
3	T _{DIS}	Transmitter Disable. Laser output disabled on high or open.	2
4	MOD_DEF(2)	Module Definition 2. Data line for Serial ID.	3
5	MOD_DEF(1)	Module Definition 1. Clock line for Serial ID.	3
6	MOD_DEF(0)	Module Definition 0. Grounded within the module.	3
7	Rate Select	No connection required	
8	LOS	Loss of Signal indication. Logic 0 indicates normal operation.	4
9	V _{EER}	Receiver Ground (Common with Transmitter Ground)	1
10	V _{EER}	Receiver Ground (Common with Transmitter Ground)	1
11	V _{EER}	Receiver Ground (Common with Transmitter Ground)	1
12	RD-	Receiver Inverted DATA out. AC Coupled	
13	RD+	Receiver Non-inverted DATA out. AC Coupled	
14	V _{EER}	Receiver Ground (Common with Transmitter Ground)	1
15	V _{CCR}	Receiver Power Supply	
16	V _{CCT}	Transmitter Power Supply	
17	V _{EET}	Transmitter Ground (Common with Receiver Ground)	1
18	TD+	Transmitter Non-Inverted DATA in. AC Coupled.	
19	TD-	Transmitter Inverted DATA in. AC Coupled.	
20	V _{EET}	Transmitter Ground (Common with Receiver Ground)	1

Notes:

1. Circuit ground is internally isolated from chassis ground.
2. Laser output disabled on TDIS >2.0V or open, enabled on TDIS <0.8V.
3. Should be pulled up with 4.7k – 10kohms on host board to a voltage between 2.0V and 3.6V. MOD_DEF(0) pulls line low to indicate module is plugged in.
4. LOS is open collector output. Should be pulled up with 4.7k – 10kohms on host board to a voltage between 2.0V and 3.6V. Logic 0 indicates normal operation; logic 1 indicates loss of signal.

Ordering information:

Part Number	Product Description
PTP4232-3L	1310nm, 155Mbps, LC, 20km, 0°C~+70°C
PTP4252-3L	1550nm, 155Mbps, LC, 20km, 0°C~+70°C
PTP4232D-3L	1310nm, 155Mbps, LC, 20km, 0°C~+70°C, With Digital Diagnostic Monitoring

[SFP 155Mb/s Optical Transceiver without DDMI \(PTP4232-3L & PTP4252-3L\)
Hot Pluggable, 1310/1550 FP-LD SFP with LC Receptacle](#)

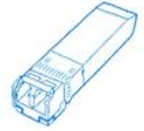

PTP4252D-3L	1550nm, 155Mbps, LC, 20km, 0°C~+70°C, With Digital Diagnostic Monitoring
PTP4232-3IL	1310nm, 155Mbps, LC, 20km, -40°C~+85°C
PTP4252-3IL	1550nm, 155Mbps, LC, 20km, -40°C~+85°C
PTP4232D-3IL	1310nm, 155Mbps, LC, 20km, -40°C~+85°C, With Digital Diagnostic Monitoring
PTP4252D-3IL	1550nm, 155Mbps, LC, 20km, -40°C~+85°C, With Digital Diagnostic Monitoring

Mechanical Dimensions:

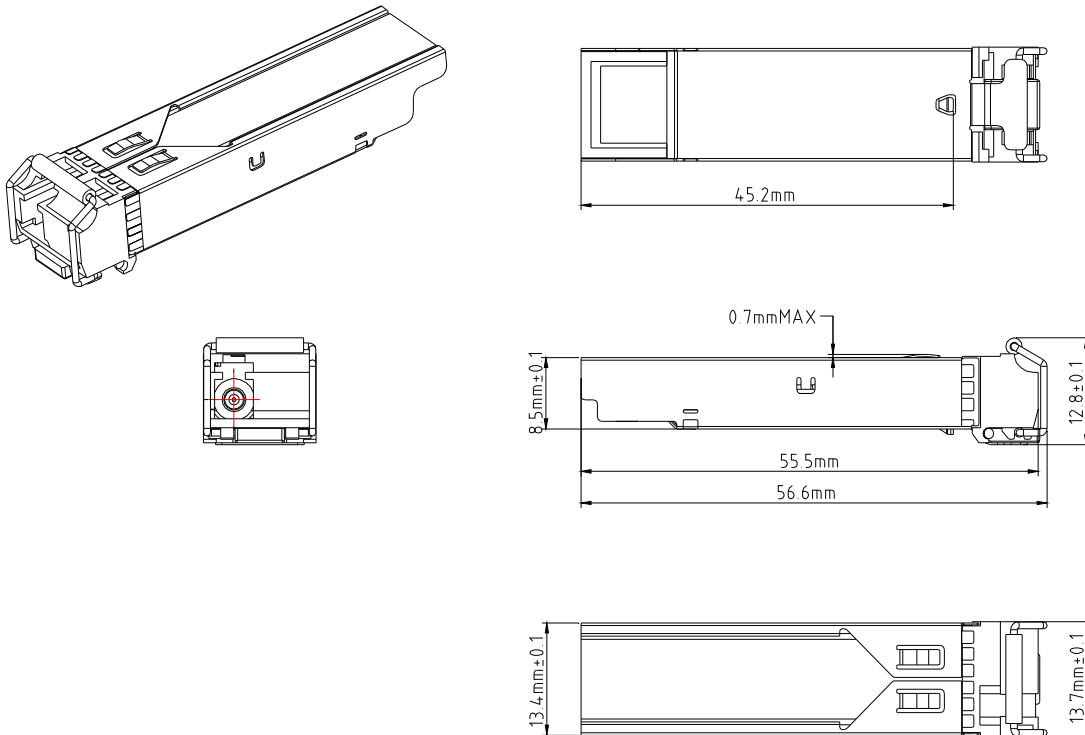

Recommended Circuit:

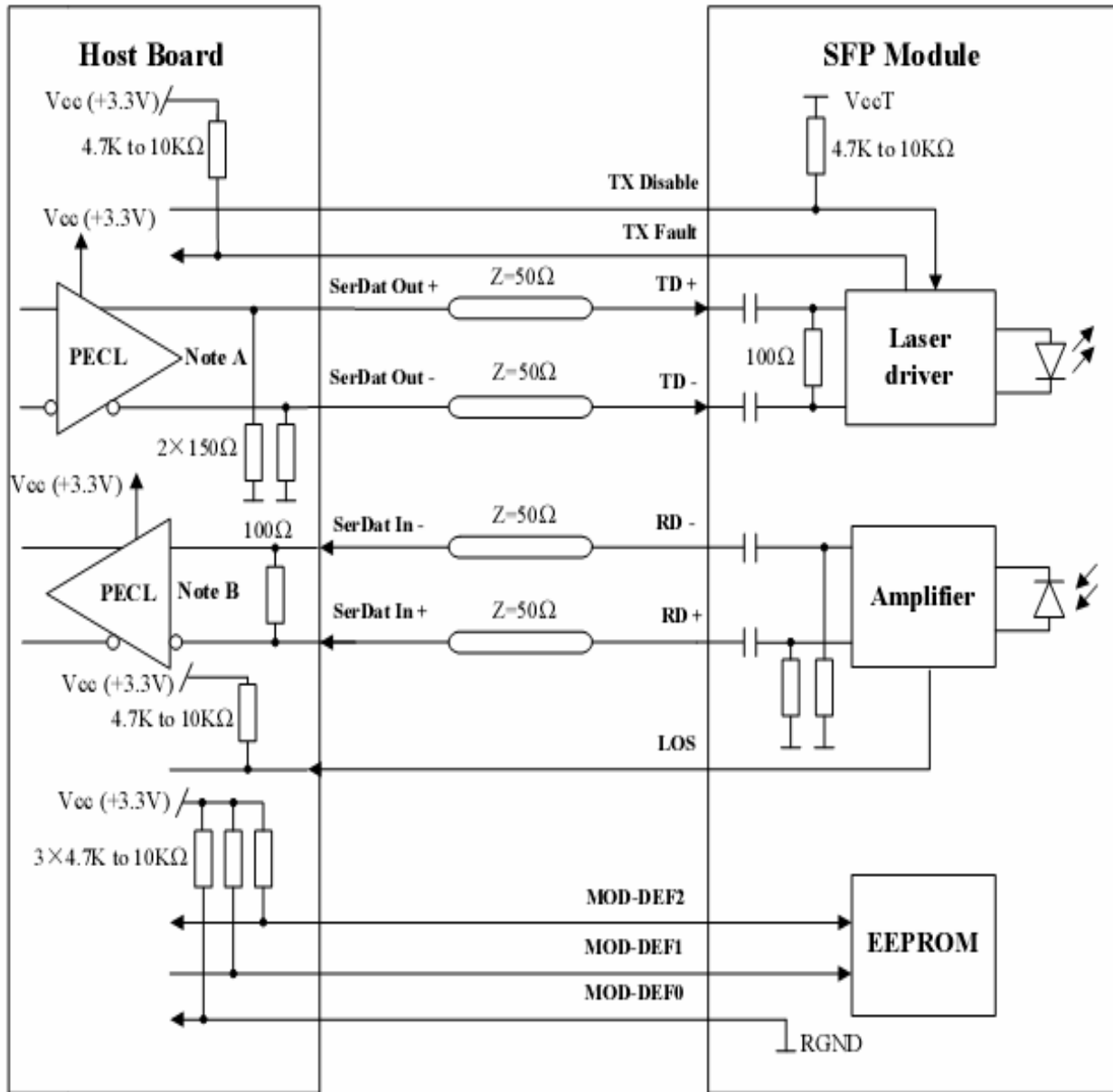
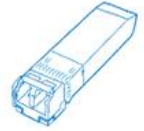

Note A: Circuit assumes open emitter output

Note B: Circuit assumes high impedance internal bias @Vcc-1.3V