



Product Specification

10Gbps/OC192 CDR SFP+ DWDM C-BAND 50/100GHz Transceiver

PLSFPP192GDMB16-xx

PLSFPP192GDMB24-xx

V20140819

Product Features

- I Up to 11.3Gbps data links
- I 40km to 80km with 9/125μm SMF *1
- I DWDM C-BAND EML laser *1
- I Duplex LC Connector
- I Hot-pluggable SFP+ footprint
- I Single 3.3V power supply
- I Operating temperature: 0°C to 70°C
- I RoHS
- I Digital Diagnostic Monitor(DDM)
- I Power Consumption:2W~2.5W *1
- I CDR

Applications

- √ DWDM 10GBase SFP+
- √ 10G FC
- √ SDH/SONET OC192/ STM64

*1 Notice

Part No.	Laser	Power Budget	Power Consumption
PLSFPP192GDMB16-XX	EML/PIN	16dB	2W
PLSFPP192GDMB24-XX	EML/APD	24dB	2.5W



1. Product Description

The **PLSFPP192GDMB16-XX/ PLSFPP192GDMB24-XX** is a 11.3Gbps enhanced small form factor pluggable SFP+ transceiver compatible with DWDM 10GBASE/10GFC/SDH. It is suitable for 40km single-mode fiber (SMF) communications in 10Gbps Ethernet.

PLSFPP192GDMB16-XX/ PLSFPP192GDMB24-XX
XX: DWDM C-BAND Channel number
* Please refer to the list in next page

Channel #	TINOUT Part Number	Frequency (THz)	Center Wave (nm)
21	PLSFPP10GDM40-21	192.1	1560.61
22	PLSFPP10GDM40-22	192.2	1559.79
23	PLSFPP10GDM40-23	192.3	1558.98
24	PLSFPP10GDM40-24	192.4	1558.17
25	PLSFPP10GDM40-25	192.5	1557.36
26	PLSFPP10GDM40-26	192.6	1556.55
27	PLSFPP10GDM40-27	192.7	1555.75
28	PLSFPP10GDM40-28	192.8	1554.94
29	PLSFPP10GDM40-29	192.9	1554.13
30	PLSFPP10GDM40-30	193.0	1553.33
31	PLSFPP10GDM40-31	193.1	1552.52
32	PLSFPP10GDM40-32	193.2	1551.72
33	PLSFPP10GDM40-33	193.3	1550.92
34	PLSFPP10GDM40-34	193.4	1550.12
35	PLSFPP10GDM40-35	193.5	1549.32
36	PLSFPP10GDM40-36	193.6	1548.51
37	PLSFPP10GDM40-37	193.7	1547.72
38	PLSFPP10GDM40-38	193.8	1546.92
39	PLSFPP10GDM40-39	193.9	1546.12
40	PLSFPP10GDM40-40	194.0	1545.32
41	PLSFPP10GDM40-41	194.1	1544.53
42	PLSFPP10GDM40-42	194.2	1543.73
43	PLSFPP10GDM40-43	194.3	1542.94
44	PLSFPP10GDM40-44	194.4	1542.14
45	PLSFPP10GDM40-45	194.5	1541.35
46	PLSFPP10GDM40-46	194.6	1540.56
47	PLSFPP10GDM40-47	194.7	1539.77
48	PLSFPP10GDM40-48	194.8	1538.98



49	PLSFPP10GDM40-49	194.9	1538.19
50	PLSFPP10GDM40-50	195.0	1537.40
51	PLSFPP10GDM40-51	195.1	1536.61
52	PLSFPP10GDM40-52	195.2	1535.82
53	PLSFPP10GDM40-53	195.3	1535.04
54	PLSFPP10GDM40-54	195.4	1534.25
55	PLSFPP10GDM40-55	195.5	1533.47
56	PLSFPP10GDM40-56	195.6	1532.68
57	PLSFPP10GDM40-57	195.7	1531.90
58	PLSFPP10GDM40-58	195.8	1531.12
59	PLSFPP10GDM40-59	195.9	1530.33

2. Regulatory Compliance

TINOUT transceivers are Class 1 Laser Products comply with FDA regulations. Meet Class 1 eye safety requirements of EN 60825 and the electrical safety requirements of EN 60950.

3. Absolute Maximum Ratings

Parameter	Symbol	Min.	Max.	Unit
Supply Voltage	Vcc	-0.5	4	V
Storage Temperature	Ts	-40	85	°C
Operating Case Temperature	Tc	0	70	°C

4. Recommended Operating Conditions

Parameter	Symbol	Min.	Typical	Max.	Unit
Operating Case Temperature	Tc	0		70	°C
Power Supply Voltage	Vcc	3.15	3.3	3.45	V
Power Supply Current	Icc			350	mA
Data Rate			10		GBps
Max Link Length on 9/125µm SMF	Lmax	Ref *1 Notice			



5. Optical Characteristics

Parameter	Symbol	Min.	Typical	Max.	Unit
Transmitter					
Centre Wavelength *1	λ_c	X-100	X	X+100	pm
Centre Wavelength Spacing			0.8		nm
Spectral Width (RMS)	σ			0.3	nm
Average Output Power PLSFPP192GDMB16-XX	P _{out}	-2		5	dBm
Average Output Power PLSFPP192GDMB24-XX	P _{out}	0		5	dBm
Extinction Ratio PLSFPP192GDMB16-XX	ER	8			dB
Extinction Ratio PLSFPP192GDMB24-XX	ER	9			dB
Average Launch Power of Off Transmitter	P _{off}			-30	dBm
Relative Intensity Noise	RIN			-130	dB/Hz
Receiver					
Centre Wavelength	λ_c	1200		1600	nm
Receiver Sensitivity PLSFPP192GDMB16-XX	P _{IN}			-16	dBm
Receiver Sensitivity PLSFPP192GDMB24-XX	P _{IN}			-24	dBm
Receiver Overload PLSFPP192GDMB16-XX	P _{max}	5			dBm
Receiver Overload PLSFPP192GDMB24-XX	P _{max}	-7			dBm
LOS De-Assert	LOS _D			-33	dBm
LOS Assert	LOS _A	-36			dBm
LOS Hysteresis		0.5		4.5	dB

*1. X= Center Wavelength. Wavelength stability is achieved within 60 seconds of power up



6. Electrical Characteristics

Parameter	Symbol	Min.	Typical	Max.	Unit
Transmitter					
Input Differential Impedance	Zin	90	100	110	Ω
Data Input Swing Differential	Vin	250		1200	mV
Tx-Dis Disable	Vd	2.0		Vcc	V
Tx-Dis Enable	Ven	0		0.8	V
Receiver					
Data Output Swing Differential	Vout	250		800	mV
Rx-Los Fault	Vlf	2.0		VccHOST	V
Rx-Los Normal	Vln	0		0+0.8	V
Output rise and fall time	Tr, Tf	30			ps

7. Pin Descriptions

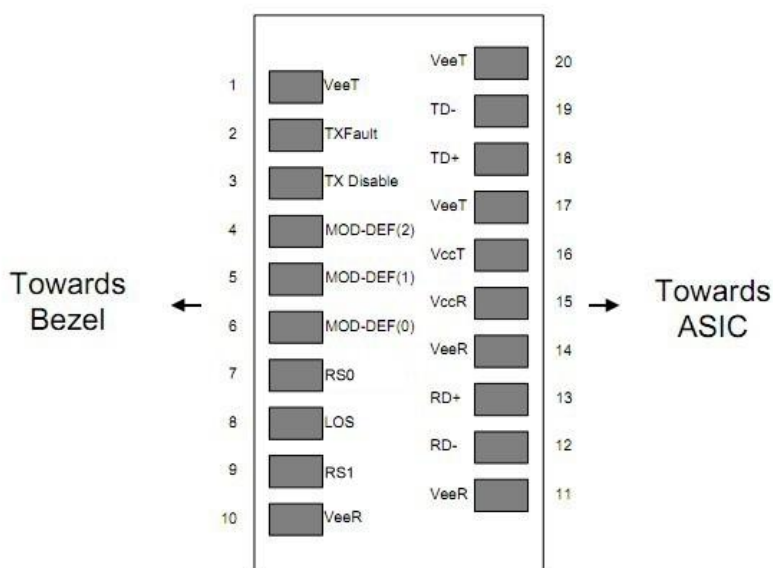

Diagram of Host Board Connector Block Pin Numbers and Names

Pin	Symbol	Description	Ref.
1	VEET	Transmitter Ground (Common with Receiver Ground)	7.1
2	TFAULT	Transmitter Fault. Not supported.	



3	TDIS	Transmitter Disable. Laser output disabled on high or open.	7.2
4	MOD_DEF(2)	Module Definition 2. Data line for Serial ID.	7.3
5	MOD_DEF(1)	Module Definition 1. Clock line for Serial ID.	7.3
6	MOD_DEF(0)	Module Definition 0. Grounded within the module.	7.3
7	RS0	Rate Select0, optionally controls SFP+ module receiver. When high input signaling rate > 4.25 GBd and when low input signaling rate < 4.25 GBd	
8	LOS	Loss of Signal indication. Logic 0 indicates normal operation.	7.4
9	RS1	Rate Select1, optionally controls SFP+ module receiver. When high input signaling rate > 4.25 GBd and when low input signaling rate < 4.25 GBd	
10	VEER	Receiver Ground (Common with Transmitter Ground)	7.1
11	VEER	Receiver Ground (Common with Transmitter Ground)	7.1
12	RD-	Receiver Inverted DATA out. AC Coupled.	
13	RD+	Receiver Non-inverted DATA out. AC Coupled.	
14	VEER	Receiver Ground (Common with Transmitter Ground)	7.1
15	VCCR	Receiver Power Supply	
16	VCCT	Transmitter Power Supply	
17	VEET	Transmitter Ground (Common with Receiver Ground)	7.1
18	TD+	Transmitter Non-Inverted DATA in. AC Coupled.	
19	TD-	Transmitter Inverted DATA in. AC Coupled.	
20	VEET	Transmitter Ground (Common with Receiver Ground)	7.1

Notes:

7.1 Circuit ground is internally isolated from chassis ground.

7.2 Laser output disabled on TDIS > 2.0V or open, enabled on TDIS < 0.8V.

7.3 Should be pulled up with 4.7k - 10kohms on host board to a voltage between 2.0V and 3.6V. MOD_DEF(0) pulls line low to indicate module is plugged in.

7.4 LOS is open collector output. Should be pulled up with 4.7k - 10kohms on host board to a voltage between 2.0V and 3.6V. Logic 0 indicates normal operation; logic 1 indicates loss of signal.

8. EEPROM & DDM THRESHOLD

8.1 EEPROM

2 wire address 1010000X (A0h)



0~95	Serial ID Defined by SFP MSA (96 bytes)
96~127	Vendor Specific (32 bytes)
128~255	Reserved (128 bytes)

EEPROM Serial ID Memory Contents

Add.	Size (Bytes)	Name of Field	Hex	Description
BASE ID FIELDS				
0	1	Identifier	03	SFP
1	1	Ext. Identifier	04	SFP function is defined by serial ID only
2	1	Connector	07	LC
3-10	8	Transceiver	80 00 00 00 00 00 00 00	Transmitter Code
11	1	Encoding	06	64B/66B
12	1	BR, Nominal	67	10.3Gbps
13	1	Reserved	00	
14	1	Length (9um) km	28	40km
15	1	Length (9um) km	FF	
16	1	OM2 Length (50um) m	00	
17	1	OM1 Length (62.5um) m	00	
18	1	Length (Copper)	00	
19	1	OM3 Length (50um) m	00	
20-35	16	Vendor Name	43 2D 4C 49 47 48 54 20 20 20 20 20 20 20 20 20	TINOUT * OEM available
36	1	Reserved	00	
37-39	3	Vendor OUI	00 00 00	* OEM available
40-55	16	Vendor PN	xx xx xx xx xx xx xx xx xx xx xx xx xx xx xx xx	* OEM available
56-59	4	Vendor Rev	30 31 20 20	01
60-61	2	Wavelength	xx xx	Center Wavelength
62	1	Reserved	00	
63	1	CC_BASE	xx	Check Code for Base ID Field
EXTENDED ID FIELDS				
64-65	2	Options	02 1A	Loss/ TX_Fault/ TX_Disable
66	1	BR, Max	00	
67	1	BR, Min	00	
68-83	16	Vendor SN	43 4C xx xx xx xx xx xx xx xx xx 20 20 20 20 20	SN of Transceiver (ASCII). Exp. "CLXXXXXXXXXX"



84-91	8	Date Code	xx xx xx xx xx xx 20 20	YY/MM/DD Exp. 120727
92	1	Diagnostic Monitoring	68	
93	1	Enhanced Options	F0	
94	1	SFF_8472 Compliance	03	
95	1	CC_EXT	checksum	Checksum for Extended ID
VENDOR SPECIFIC ID FIELDS				
96-127	32	Vendor Specific	20 20 20.....	Depends on Customer Info
128-255	128	Reserved	FF FF FF.....	Depends on Customer Info

8.1 DDM THRESHOLD

PLSFPP192GDMB16-XX

	Low Alarm	Low Warn	High Warn	High Alarm
Temperature	-5°C	0°C	70°C	75°C
Voltage	2.9V	3V	3.6V	3.7V
Tx Bias	15mA	20mA	90mA	100mA
Tx Power	-3dBm	-2dBm	5dBm	7dBm
Rx Power	-18dBm	-16dBm	5dBm	7dBm

PLSFPP192GDMB24-XX

	Low Alarm	Low Warn	High Warn	High Alarm
Temperature	-5°C	0°C	70°C	75°C
Voltage	2.9V	3V	3.6V	3.7V
Tx Bias	15mA	20mA	90mA	100mA
Tx Power	-3dBm	-2dBm	5dBm	7dBm
Rx Power	-26dBm	-24dBm	-7dBm	-6dBm

9. Mechanical Specifications

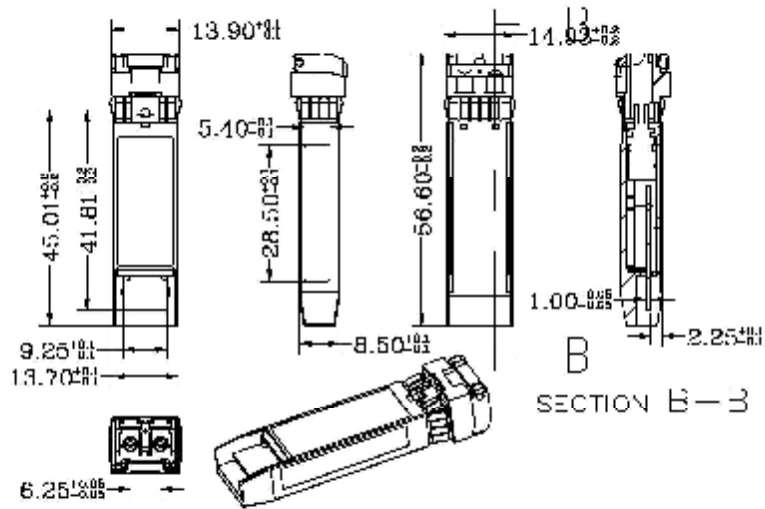

10. LABEL

TINOUT offers label OEM design and print.
 Label barcode supports code128 and 2D barcode
 SIZE: 26mm*10.5mm



Ordering Information

Part No.	Data Rate	DDM	Wave	Fiber Type	Powr Budget	Temp.	Optical Interface
PLSFPP192GDMB16-XX	11.3Gbps	yes	XX *	SMF	16dB	0~70℃	LC
PLSFPP192GDMB24-XX	11.3Gbps	yes	XX *	SMF	24dB	0~70℃	LC

* Please refer to the channel list in Page2

VERSION UPDATE:



VERSION NO.	DATE	UPDATED INFORMATION
V20140819	20140819	New Published

NOTICE:

TINOUT reserves the right to make changes to this product in this specification without notice, in order to improve product performance.

CONTACT:

TINOUT TECHNOLOGY LIMITED

E-mail: CROFT@TINOUT.com <http://www.TINOUT.com>