



Product Specification

10Gbps 850nm 300m SFP+ Transceiver

PLSFPP8510GSR

V20140818

Product Features

- | Up to 10Gbps data links
- | 300m with 50/125 μ m 2000MHz MMF
- | 850nm VCSEL laser
- | Duplex LC Connector
- | Hot-pluggable SFP+ footprint
- | Single 3.3V power supply
- | Operating temperature: -5 $^{\circ}$ C to 85 $^{\circ}$ C
- | RoHS
- | Digital Diagnostic Monitor(DDM)
- | Power Consumption < 0.8W

Applications

√ 10GBase-SR/SW 10G Ethernet

1. Product Description

The PLSFPP8510GSR is a 10Gbps enhanced small form factor pluggable SFP+ transceiver compatible with 10GBASE-SR/SW. It is suitable for multi-mode fiber (MMF) communications in 10Gbps Ethernet.

2. Regulatory Compliance

TINOUT transceivers are Class 1 Laser Products comply with FDA regulations. Meet Class 1 eye safety requirements of EN 60825 and the electrical safety requirements of EN 60950.

3. Absolute Maximum Ratings



Parameter	Symbol	Min.	Max.	Unit
Supply Voltage	V _{CC}	-0.5	4	V
Storage Temperature	T _s	-40	85	°C
Operating Case Temperature	T _c	-5	85	°C

4. Recommended Operating Conditions

Parameter	Symbol	Min.	Typical	Max.	Unit
Operating Case Temperature	T _c	-5		85	°C
Power Supply Voltage	V _{CC}	3.15	3.3	3.45	V
Power Supply Current	I _{CC}			200	mA
Data Rate			10		GBps
Max Link Length on 50/125µm 2000MHz MMF	L _{max}			300	m

5. Optical Characteristics

Parameter	Symbol	Min.	Typical	Max.	Unit
Transmitter					
Centre Wavelength	λ_c	840	850	860	nm
Spectral Width (RMS)	σ			0.5	nm
Average Output Power	P _{out}	-5		-1	dBm
Extinction Ratio	ER	3.5			dB
Average Launch Power of Off Transmitter	P _{off}			-30	dBm
Receiver					
Centre Wavelength	λ_c	840		860	nm
Receiver Sensitivity	P _{IN}			-13	dBm
Receiver Overload	P _{max}	0.5			dBm
LOS De-Assert	LOS _D			-18	dBm
LOS Assert	LOS _A	-30			dBm
LOS Hysteresis		0.5			dB

6. Electrical Characteristics

Parameter	Symbol	Min.	Typical	Max.	Unit
-----------	--------	------	---------	------	------



Transmitter					
Input Differential Impedance	Zin	90	100	110	Ω
Data Input Swing Differential	Vin	200		700	mV
Tx-Dis Disable	Vd	2.0		Vcc	V
Tx-Dis Enable	Ven	0		0.8	V
Receiver					
Data Output Swing Differential	Vout	300		800	mV
Rx-Los Fault	Vlf	2.0		VccHOST	V
Rx-Los Normal	Vln	0		0+0.8	V
Output rise and fall time	Tr, Tf	28			ps

7. Pin Descriptions

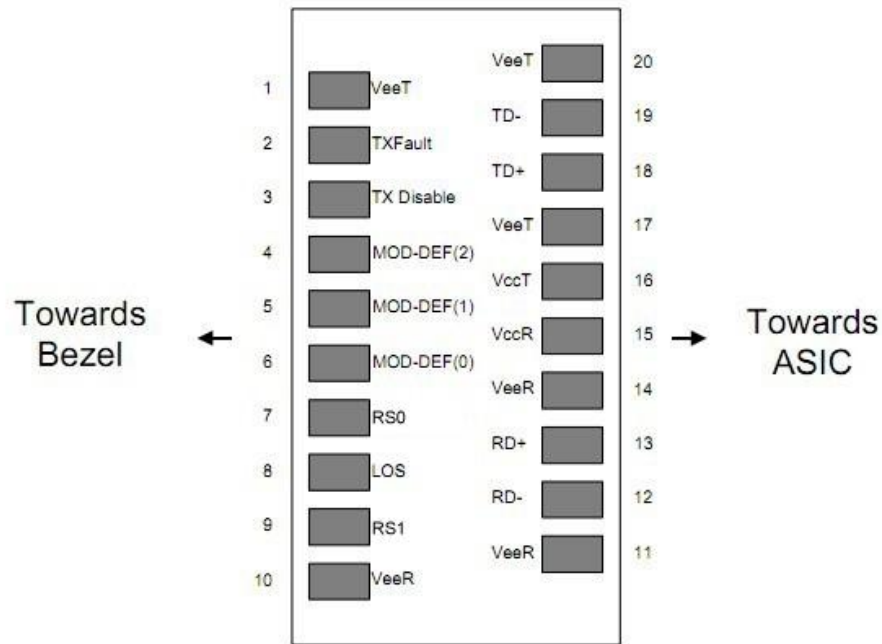

Diagram of Host Board Connector Block Pin Numbers and Names



Pin	Symbol	Description	Ref.
1	VEET	Transmitter Ground (Common with Receiver Ground)	7.1
2	TFAULT	Transmitter Fault. Not supported.	
3	TDIS	Transmitter Disable. Laser output disabled on high or open.	7.2
4	MOD_DEF(2)	Module Definition 2. Data line for Serial ID.	7.3
5	MOD_DEF(1)	Module Definition 1. Clock line for Serial ID.	7.3
6	MOD_DEF(0)	Module Definition 0. Grounded within the module.	7.3
7	RS0	Rate Select0, optionally controls SFP+ module receiver. When high input signaling rate > 4.25 GBd and when low input signaling rate < 4.25 GBd	
8	LOS	Loss of Signal indication. Logic 0 indicates normal operation.	7.4
9	RS1	Rate Select1, optionally controls SFP+ module receiver. When high input signaling rate > 4.25 GBd and when low input signaling rate < 4.25 GBd	
10	VEER	Receiver Ground (Common with Transmitter Ground)	7.1
11	VEER	Receiver Ground (Common with Transmitter Ground)	7.1
12	RD-	Receiver Inverted DATA out. AC Coupled.	
13	RD+	Receiver Non-inverted DATA out. AC Coupled.	
14	VEER	Receiver Ground (Common with Transmitter Ground)	7.1
15	VCCR	Receiver Power Supply	
16	VCCT	Transmitter Power Supply	
17	VEET	Transmitter Ground (Common with Receiver Ground)	7.1
18	TD+	Transmitter Non-Inverted DATA in. AC Coupled.	
19	TD-	Transmitter Inverted DATA in. AC Coupled.	
20	VEET	Transmitter Ground (Common with Receiver Ground)	7.1

Notes:

7.1 Circuit ground is internally isolated from chassis ground.

7.2 Laser output disabled on TDIS > 2.0V or open, enabled on TDIS < 0.8V.

7.3 Should be pulled up with 4.7k - 10kohms on host board to a voltage between 2.0V and 3.6V. MOD_DEF(0) pulls line low to indicate module is plugged in.

7.4 LOS is open collector output. Should be pulled up with 4.7k - 10kohms on host board to a voltage between 2.0V and 3.6V. Logic 0 indicates normal operation; logic 1 indicates loss of signal.



8. EEPROM & DDM THRESHOLD

8.1 EEPROM

2 wire address 1010000X (A0h)

0~95 Serial ID Defined by SFP MSA (96 bytes)
96~127 Vendor Specific (32 bytes)
128~255 Reserved (128 bytes)

EEPROM Serial ID Memory Contents

Addr.	Size (Bytes)	Name of Field	Hex	Description
BASE ID FIELDS				
0	1	Identifier	03	SFP
1	1	Ext. Identifier	04	SFP function is defined by serial ID only
2	1	Connector	07	LC
3-10	8	Transceiver	10 00 00 00 00 00 00 00	Transmitter Code
11	1	Encoding	06	64B/66B
12	1	BR, Nominal	67	10.3Gbps
13	1	Reserved	00	
14	1	Length (9um) km	00	80m
15	1	Length (9um) km	00	
16	1	OM2 Length (50um) m	08	
17	1	OM1 Length (62.5um) m	02	20m
18	1	Length (Copper)	00	
19	1	OM3 Length (50um) m	1E	30m
20-35	16	Vendor Name	43 2D 4C 49 47 48 54 20 20 20 20 20 20 20 20 20	TINOUT * OEM available
36	1	Reserved	00	
37-39	3	Vendor OUI	00 00 00	* OEM available
40-55	16	Vendor PN	xx xx xx xx xx xx xx xx xx xx xx xx xx xx xx xx	* OEM available
56-59	4	Vendor Rev	30 31 20 20	01
60-61	2	Wavelength	03 52	850nm
62	1	Reserved	00	
63	1	CC_BASE	xx	Check Code for Base ID Field



EXTENDED ID FIELDS				
64-65	2	Options	00 1A	Loss/ TX_Fault/ TX_Disable
66	1	BR, Max	00	
67	1	BR, Min	00	
68-83	16	Vendor SN	43 4C xx xx xx xx xx xx xx xx xx 20 20 20 20	SN of Transceiver (ASCII). Exp. "CLXXXXXXXXXX"
84-91	8	Date Code	xx xx xx xx xx xx 20 20	YY/MM/DD Exp. 120727
92	1	Diagnostic Monitoring	68	
93	1	Enhanced Options	80	
94	1	SFF_8472 Compliance	03	
95	1	CC_EXT	checksum	Checksum for Extended ID
VENDOR SPECIFIC ID FIELDS				
96-127	32	Vendor Specific	20 20 20.....	Depends on Customer Info
128-255	128	Reserved	FF FF FF.....	Depends on Customer Info

8.1 DDM THRESHOLD

	Low Alarm	Low Warn	High Warn	High Alarm
Temperature	-13°C	-8°C	88°C	93°C
Voltage	2.9V	3V	3.6V	3.7V
Tx Bias	4mA	5mA	10.8mA	11.8mA
Tx Power	-6dBm	-5dBm	-1dBm	0dBm
Rx Power	-16dBm	-14dBm	-1dBm	0dBm

9. Mechanical Specifications

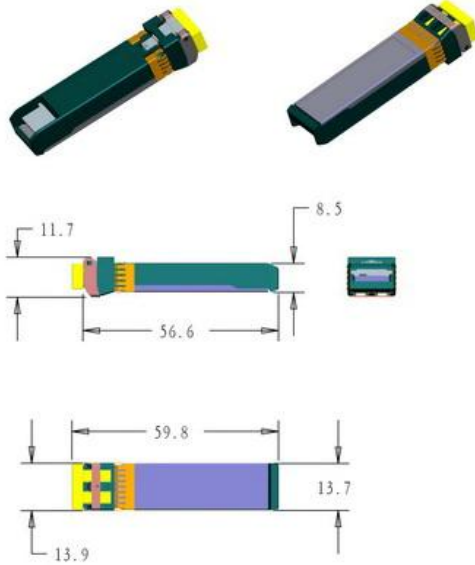

10. LABEL

TINOUT offers label OEM design and print.

Label barcode supports code128 and 2D barcode

SIZE: 1) Front 35mm*10.5mm 2)Back 26mm*10.5mm



Ordering Information

Part No.	Data Rate	DDM	Wave	Fiber Type	Dist.	Temp.	Optical Interface
PLSFPP8510GSR	10Gbps	yes	850nm	MMF	300m	-5~85℃	LC

VERSION UPDATE:

VERSION NO.	DATE	UPDATED INFORMATION
V20140818	20140818	1. EEPROM& DDM Threshold updated 2. "LABEL" added 3. Ordering information updated 4. Product picture updated

**NOTICE:**

TINOUT reserves the right to make changes to this product in this specification without notice, in order to improve product performance.

CONTACT:

TINOUT TECHNOLOGY LIMITED

E-mail: CROFT@TINOUT.com <http://www.tinout.com>