



Product Specification

10Gbps XFP Transceiver

PLXFP8510GSR

V20140818

Product Features

- | 9.95Gbps to 11.1Gbps data links
- | 300m with 50/125 μ m 2000MHz MMF
- | 850nm VCSEL laser
- | Duplex LC Connector
- | Hot-pluggable XFP footprint
- | Single 3.3V power supply
- | Operating temperature: -5 $^{\circ}$ C to 85 $^{\circ}$ C
- | RoHS
- | Digital Diagnostic Monitor (DDM)
- | Power Consumption <1.5W

Applications

- √ 10GBase-SR/SW 10G Ethernet
- √ 1200-Mx-SN-I 10G FC

1. Product Description

The PLXFP8510GSR is a 10Gbps enhanced small form factor pluggable XFP transceiver compatible with 10GBASE-SR/SW and 1200-Mx-SN-I 10G FC. It is suitable for multi-mode fiber (MMF) communications in 10Gbps Ethernet/FC.

2. Regulatory Compliance

TINOUT transceivers are Class 1 Laser Products comply with FDA regulations. Meet Class 1 eye safety requirements of EN 60825 and the electrical safety requirements of EN 60950.



3. Absolute Maximum Ratings

Parameter	Symbol	Min.	Max.	Unit
Supply Voltage	V _{CC}	-0.5	4	V
Storage Temperature	T _s	-40	85	°C
Operating Case Temperature	T _c	-5	85	°C

4. Recommended Operating Conditions

Parameter	Symbol	Min.	Typical	Max.	Unit
Operating Case Temperature	T _c	-5		85	°C
Power Supply Voltage	V _{CC}	3.15	3.3	3.45	V
Power Supply Current	I _{CC}			400	mA
Data Rate			10		GBps
Max Link Length on 50/125µm 2000MHz MMF	L _{max}			300	m

5. Optical Characteristics

Parameter	Symbol	Min.	Typical	Max.	Unit
Transmitter					
Centre Wavelength	λ_c	840	850	860	nm
Spectral Width (RMS)	σ			0.5	nm
Average Output Power	P _{out}	-5		-1	dBm
Extinction Ratio	ER	3.5			dB
Average Launch Power of Off Transmitter	P _{off}			-30	dBm
Receiver					
Centre Wavelength	λ_c	840		860	nm
Receiver Sensitivity	P _{IN}			-11	dBm
Receiver Overload	P _{max}	0.5			dBm
LOS De-Assert	LOS _D			-18	dBm
LOS Assert	LOS _A	-30			dBm
LOS Hysteresis		0.5			dB



6. Electrical Characteristics

Parameter	Symbol	Min.	Typical	Max.	Unit
Transmitter					
Input Differential Impedance	Zin	90	100	110	Ω
Data Input Swing Differential	Vin	200		700	mV
Tx-Dis Disable	Vd	2.0		Vcc	V
Tx-Dis Enable	Ven	0		0.8	V
Receiver					
Data Output Swing Differential	Vout	300		800	mV
Rx-Los Fault	Vlf	2.0		Vcchost	V
Rx-Los Normal	Vln	0		0+0.8	V
Output rise and fall time	Tr, Tf	28			ps

7. Pin Descriptions

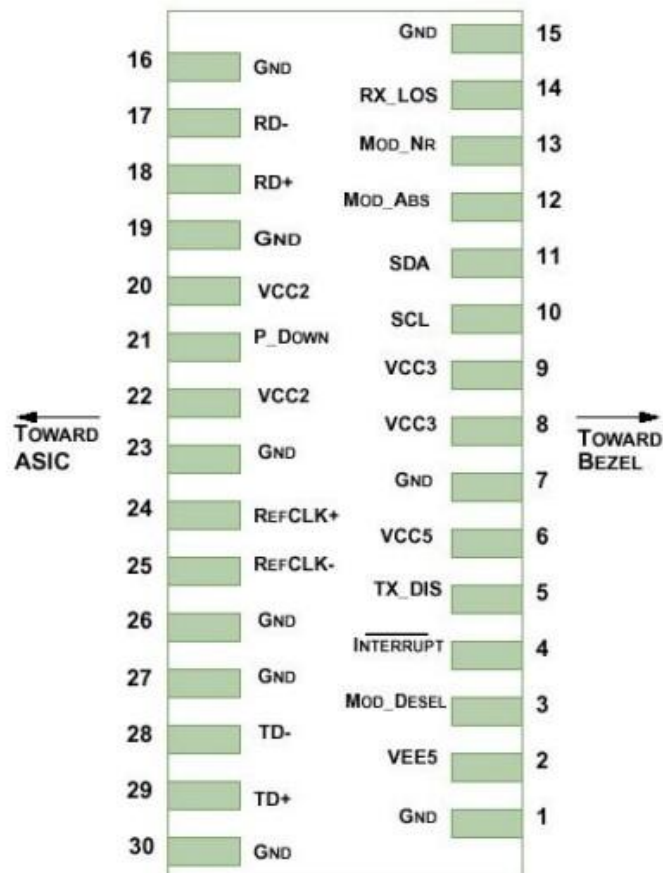



Pin	Symbol	Description	Ref.
1	GND	Module Ground	
2	VEE5	Optional Power Supply	
3	Mod-Desel		
4	Interrupt		
5	Tx-Dis	Transmitter Disable	
6	VCC5	+5V Power Supply	
7	GND	Module Ground	
8	VCC3	+3.3V Power Supply	
9	VCC3	+3.3V Power Supply	
10	SCL	Serial 2wire interface clock	
11	SDA	Serial 2wire interface data line	
12	Mod-Abs	Module Absent	
13	Mod-NR	Module Not Ready	
14	Rx-Los	Receiver Loss of Signal indicator	
15	GND	Module Ground	
16	GND	Module Ground	
17	RD-	Receiver Inverted data output	
18	RD+	Receiver non-Inverted data output	
19	GND	Module Ground	
20	VCC2	+1.8V Power Supply	
21	P-Down/RST		
22	VCC2	+1.8V Power Supply	
23	GND	Module Ground	
24	Ref CLK+		
25	Ref CLK-		
26	GND	Module Ground	
27	GND	Module Ground	
28	TD-	Transmitter Inverted data input	
29	TD+	Transmitter non-Inverted data input	
30	GND	Module Ground	

8. EEPROM & DDM THRESHOLD



8.1 EEPROM

TABLE (00h)

Reserved for diagnostics functions

TABLE (01h) EEPROM Serial ID Memory Contents

Addr.	Size (Bytes)	Name of Field	Hex	Description
BASE ID FIELDS				
128	1	Identifier	06	XFP
129	1	Ext. Identifier	10	TX Ref Clock Input Not Required; Power Consumption Max 1.5W
130	1	Connector	07	LC
131-138	8	Transceiver	88 80 00 00 00 00 00 00	Transmitter Code
139	1	Encoding	F0	64B/66B, 8B/10B, SONET, NRZ
140	1	BR, Min	63	9.9Gbps
141	1	BR, Min	6F	11.1Gbps
142	1	Length (9um) km	00	300m 82m 26m
143	1	Length (E-50um) m	96	
144	1	Length (50um) m	52	
145	1	Length (62.5um) m	1A	
146	1	Length (Copper)	00	
147	1	Device Tech	00	850nm VCSEL
148-163	16	Vendor Name	43 2D 4C 49 47 48 54 20 20 20 20 20 20 20 20 20	TINOUT * OEM available
164	1	CDR Support	F8	9.9~11.1Gbps
165-167	3	Vendor OUI	00 00 00	* OEM available
168-183	16	Vendor PN	xx xx xx xx xx xx xx xx xx xx xx xx xx xx xx xx	* OEM available
184-185	2	Vendor Rev	30 31	01
186-187	2	Wavelength	42 68	850nm
188-189	2	Wavelength Tolerance	0F A0	20nm
190	1	Max Case Temp	46	70°C
191	1	CC-BASE		
EXTENDED ID FIELDS				
192-195	4	Power Supply	4B	Max Power Consumption 1.5W
			96	Max Power Consumption in



			04 00	Power Down Mode is 1.5W Max Current by 3.3V is 400mA
196-211	16	Vendor SN	43 4C xx xx xx xx xx xx xx xx xx 20 20 20 20 20	SN of Transceiver (ASCII). Exp. "PLXXXXXXXXXX"
212-219	8	Date Code	xx xx xx xx xx xx 20 20	YY/MM/DD Exp. 120727
220	1	Diagnostic Monitoring	08	Average Power
221	1	Enhanced Options	40	Optional Soft TX_DISABLE implemented;
222	1	Aux Monitoring	70	
223	1	CC_EXT	checksum	Checksum for Extended ID
VENDOR SPECIFIC ID FIELDS				
224-255	32	Vendor Specific	FF FF FF.....	Depends on Customer Info

8.1 DDM THRESHOLD

	Low Alarm	Low Warn	High Warn	High Alarm
Temperature	-10°C	-5°C	75°C	80°C
Voltage	2.9V	3V	3.6V	3.7V
Tx Bias	4mA	5mA	10.8mA	11.8mA
Tx Power	-7dBm	-6dBm	-1dBm	0dBm
Rx Power	-15dBm	-13dBm	-1dBm	0dBm

9. Mechanical Specifications

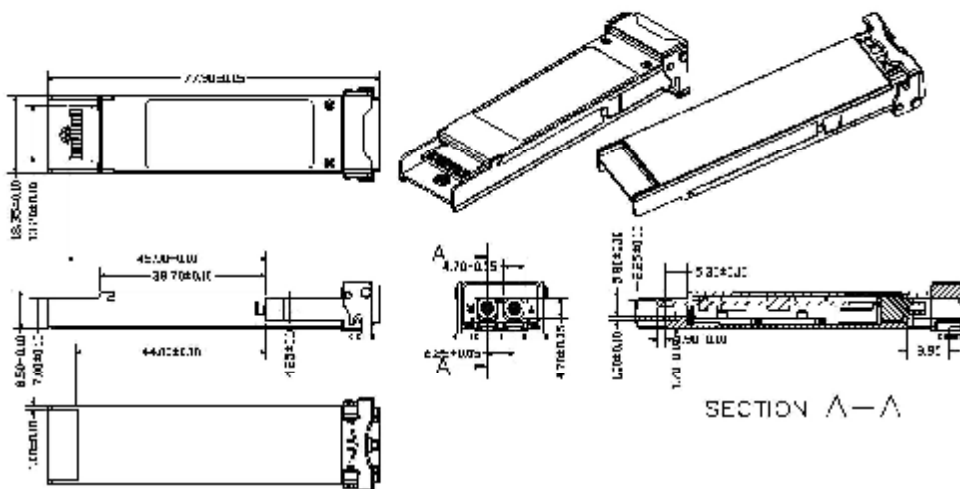

10. LABEL



TINOUT offers label OEM design and print.
 Label barcode supports code128 and 2D barcode
 SIZE: 38mm*15mm



Ordering Information

Part No.	Data Rate	DDM	Wave	Fiber Type	Dist.	Temp.	Optical Interface
PLXFP8510GSR	9.95Gbps ~11.1Gbps	yes	850nm	MMF	300m	-5~85℃	LC

VERSION UPDATE:

VERSION NO.	DATE	UPDATED INFORMATION
V20140818	20140818	1. EEPROM& DDM Threshold updated 2. "LABEL" added 3. Ordering information updated 4. Product picture updated

NOTICE:

TINOUT reserves the right to make changes to this product in this specification without notice, in order to improve product performance.

CONTACT:

TINOUT TECHNOLOGY LIMITED

E-mail: CROFT@TINOUT.com <http://www.tinout.com>