



X2-10GB-ZR

X2-10GBASE-ZR 1550nm, 80km Reach

Features

- | Compatible with X2 MSA Rev2.0b
- | Support of IEEE 802.3ae 10GBASE-ER at 10.3125Gbps
- | Transmission Distance up to 80Km(SMF)
- | SC Receptacle 1550nm Cooled EA-DFB Laser
- | SC Duplex Optical Connector
- | Hot Pluggable 70-PIN Connector with XAUI Electrical Interface
- | Management and control via MDIO 2-wire interface
- | Power Supply : +5V, +3.3V, APS(+1.2V)
- | Diagnostic Optics Monitoring
- | Temperature Range: 0~ 70 °C
- | ROHS Compatible



Applications

- | 10GE Ethernet switches and routers
- | 10GE Core-routers
- | 10GE Storage
- | Other 10Gbps Ethernet Transmission System

Product Description

The X2-10GB-ZR is a highly integrated, Serial optical transponder module for high-speed, 10Gbit/s data transmission applications. 4x3.125Gbps Ethernet Signal Input by XAUI Interface. An integrated Coder / Decoder and multiplexer / demultiplexer (SERDES: Serializer / Deserializer). Designing for 80km Transmission with an uncooled directly modulated 1550nm Cooled EA-DFB Laser. Digital diagnostics functions are available via a 2-wire serial interface, as specified in the XENPAK MSA 3.0.

Absolute Maximum Ratings



Parameter	Symbol	Min	Max	Unit
Supply Voltage+5V	Vcc5		6.0	V
Supply Voltage_3.3V	Vcc3		4	V
Supply Voltage APS	Vaps		2	V
Storage Temperature	Tst	-20	85	°C
Optical Input Received Power	APD	-	-7	dBm

Any stress beyond the maximum ratings can result in permanent damage. The device specifications are guaranteed only under the recommended operating conditions.

Recommended Operating Conditions

Parameter	Symbol	Min	Typical	Max	Unit
Operating Case temperature	Tca	0	-	70	°C
Supply Voltage+5V	Vcc5	4.75	5	5.25	V
Supply Current+5V	Icc5			500	mA
Supply Voltage_3.3V	VCC3	3.14	3.3	3.47	V
Supply Current+3.3V	Icc3			1000	mA
Supply Voltage APS	Vaps	1.14	1.2	1.26	V
Supply Current APS	Iaps			1100	mA
Module Power Dissipation	Pm	-		4	W

Transmitter Specifications – Optical

Parameter	Symbol	Min	Typical	Max	Unit
Center Wavelength	λ_c	1530		1565	nm
Optical Transmit Power	Po	0		4	dBm
Optical Transmit Power (disabled)	Ptx-dis	-	-	-40	dBm
Extinction Ratio	ER	9		-	dB
Side Mode Suppression Ratio	SMSR	30	-	-	dB
Eye Mask	IEEE 802.3ae Compliant				

Transmitter Specifications – Electrical



Parameter	Symbol	Min	Typical	Max	Unit
Data Rate (TXLINE0-3)	TX-xaui	-	3125	-	Mbps
Differential impedance	Zo	80	100	120	Ω
Differential Input Amplitude	Vin P-P	160	-	2000	mVpp
Input Rise/Fall	TR / TF	60	-	130	ps
Differential Impedance of Zin	Zin	-	100	-	ohm

Receiver Specifications – Optical

Parameter	Symbol	Min	Typical	Max	Unit
Received power	Rpo	-24.0	-	-7	dBm
Maximum Input Power	RX-overload	-7	-	-	dBm
Input Operating Wavelength	λ	1260	-	1565	nm
Dispersion tolerance	Dt	0	-	1600	ps/nm

Receiver Specifications – Electrical

Parameter	Symbol	Min	Typical	Max	Unit
Data Rate (TXLINE0-3)	RX-xaui		3125		Mbps
Supply Voltage	VccRX	3.13	3.3	3.47	V
Differential Output Amplitude	Vout P-P	800	-	1600	mV
Rise/Fall Time	Tr / Tf	50	-	90	ps
Differential Impedance of Zout	Zout	-	100	-	ohm

Signal Specifications – Electrical

Parameter	Symbol	Min	Typ	Max	Units
1.2 V CMOS					
Input High Voltage	VIL(MAX)	-	-	0.36	V
Input Low Voltage	VIH(MIN)	0.84	-	1.25	V
Capacitance		-	-	320	pF
Pull Up Resistance	Rpull	10k	-	22k	ohm
MDIO I/O					
Output Low Voltage	VOL	-0.3	-	0.2	V



Output Low Current	IOL	-	-	4	mA
Input High Voltage	VIH	0.84	-	1.5	V
Input Low Voltage	VIL	-0.3	-	0.36	V
Pull-up Supply Voltage	VPULL	1.14	1.2	1.26	
Input Capacitance	CIN	-	-	10	Pf
Load Capacitance	CLOD	-	-	470	Pf
External Pull-up Resistance	EPULL	200	-	-	Ohm

Pin Definitions

Pin No	Name	Dir	Function	Notes
1	GND		Electrical Ground	1
2	GND		Electrical Ground	1
3	GND		Electrical Ground	1
4	5.0V		Power	2
5	3.3V		Power	2
6	3.3V		Power	2
7	APS =1.2V		Adaptive Power Supply	2
8	APS =1.2V		Adaptive Power Supply	2
9	LASI		Open Drain Compatible 10K-22K pull up on host. Logic High: Normal Operation Logic Low: LASI Asserted	4
10	RESET	I	Open Drain compatible. 10-22K pull-up on transceiver Logic high = Normal operation Logic low = Reset Minimum reset assert time 1 ms	4
11	VEND SPECIFIC		Vendor Specific Pin. Leave unconnected when not in use.	8
12	TX ON/OFF	I	Open Drain compatible. 10-22K pull-up on transceiver Logic high = Transmitter On (capable) Logic low = Transmitter Off (always)	4
13	RESERVED		Reserved	4
14	MOD DETECT	O	Pulled low inside module through 1k	
15	VEND SPECIFIC		Vendor Specific Pin. Leave unconnected when not in use.	8
16	VEND SPECIFIC		Vendor Specific Pin. Leave unconnected when not in use.	8
17	MDIO	I/O	Management Data IO	4, 5
18	MDC	I	Management Data Clock	4, 5
19	PRTAD4	I	Port Address Bit 4 (Low = 0)	4
20	PRTAD3	I	Port Address Bit 3 (Low = 0)	4



21	PRTAD2	I	Port Address Bit 2 (Low = 0)	4
22	PRTAD1	I	Port Address Bit 1 (Low = 0)	4
23	PRTAD0	I	Port Address Bit 0 (Low = 0)	4
24	VEND SPECIFIC		Vendor Specific Pin. Leave unconnected when not in use.	8
25	APS SET		Feedback input for APS	
26	RESERVED		Reserved for Avalanche Photodiode use.	8
27	APS SENSE		APS Sense Connection	
28	APS =1.2V		Adaptive Power Supply	2
29	APS =1.2V		Adaptive Power Supply	2
30	3.3V		Power	2
31	3.3V		Power	2
32	5.0V		Power	2
33	GND		Electrical Ground	1
34	GND		Electrical Ground	1
35	GND		Electrical Ground	1
36	GND		Electrical Ground	1
37	GND		Electrical Ground	1
38	RESERVED		Reserved	
39	RESERVED		Reserved	
40	GND		Electrical Ground	1
41	RX LANE0+	O	Module XAUI Output Lane 0+	7
42	RX LANE0-	O	Module XAUI Output Lane 0-	7
43	GND		Electrical Ground	1
44	RX LANE1+	O	Module XAUI Output Lane 1+	7
45	RX LANE1-	O	Module XAUI Output Lane 1-	7
46	GND		Electrical Ground	1
47	RX LANE2+	O	Module XAUI Output Lane 2+	7
48	RX LANE2-	O	Module XAUI Output Lane 2-	7
49	GND		Electrical Ground	1
50	RX LANE3+	O	Module XAUI Output Lane 3+	7
51	RX LANE3-	O	Module XAUI Output Lane 3-	7
52	GND		Electrical Ground	1
53	GND		Electrical Ground	1
54	GND		Electrical Ground	1
55	TX LANE0+	I	Module XAUI Input Lane 0+	7
56	TX LANE0-	I	Module XAUI Input Lane 0-	7
57	GND		Electrical Ground	1
58	TX LANE1+	I	Module XAUI Input Lane 1+	7



59	TX LANE1-	I	Module XAUI Input Lane 1-	7
60	GND		Electrical Ground	1
61	TX LANE2+	I	Module XAUI Input Lane 2+	7
62	TX LANE2-	I	Module XAUI Input Lane 2-	7
63	GND		Electrical Ground	1
64	TX LANE3+	I	Module XAUI Input Lane 3+	7
65	TX LANE3-	I	Module XAUI Input Lane 3-	7
66	GND		Electrical Ground	1
67	RESERVED		Reserved	
68	RESERVED		Reserved	
69	GND		Electrical Ground	1
70	GND		Electrical Ground	1

Notes:

- 1) Ground connections are common for TX and RX.
- 2) All connector contacts are rated at 0.5A nominal.
- 4) 1.2V CMOS compatible.
- 5) MDIO and MDC timing must comply with IEEE802.3ae, Clause 45.3
- 7) XAUI output characteristics should comply with IEEE802.3ae Clause 47.
- 8) Transceivers will be MSA compliant when no signals are present on the vendor specific pins.

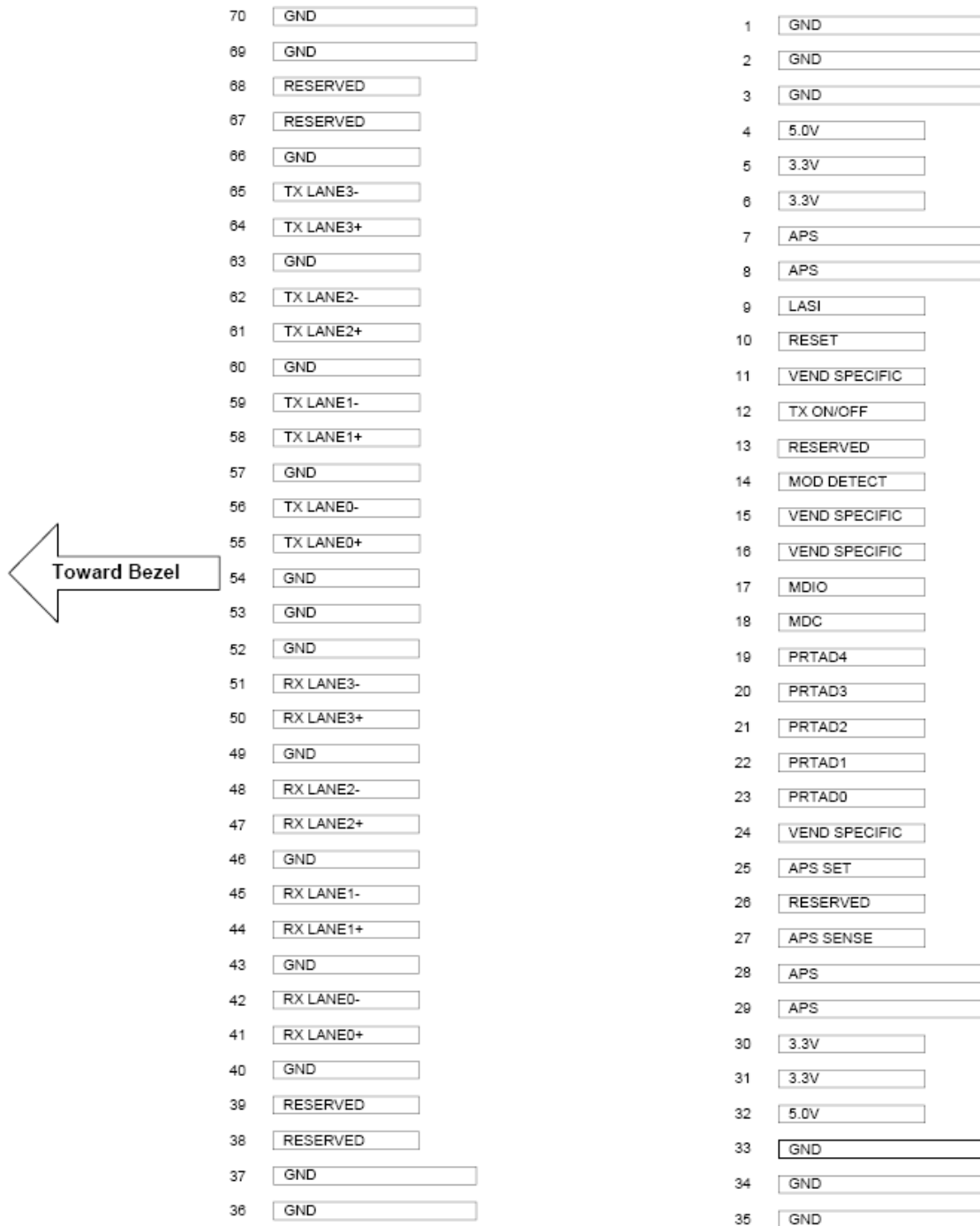

Figure1.Electrical Pin-out Details

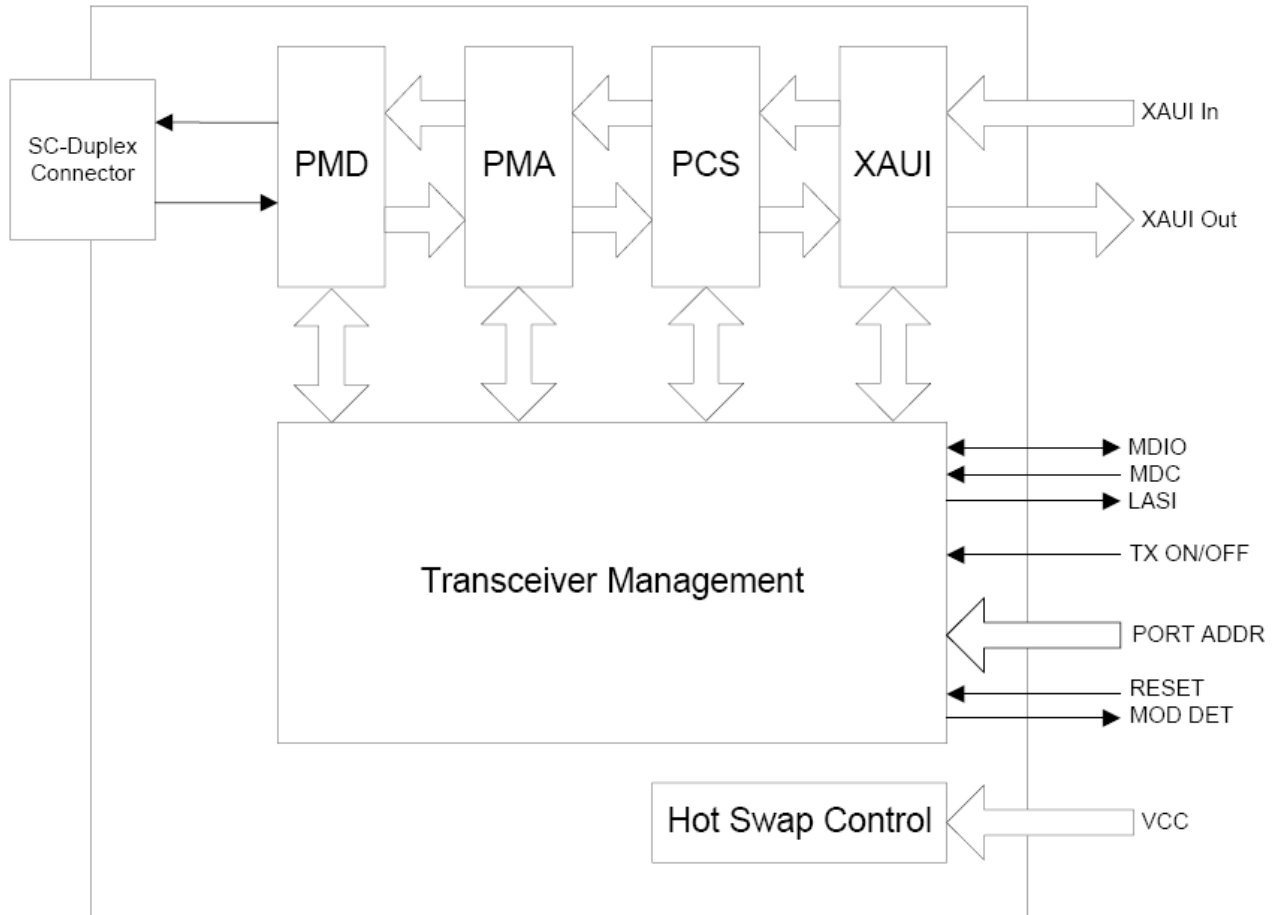
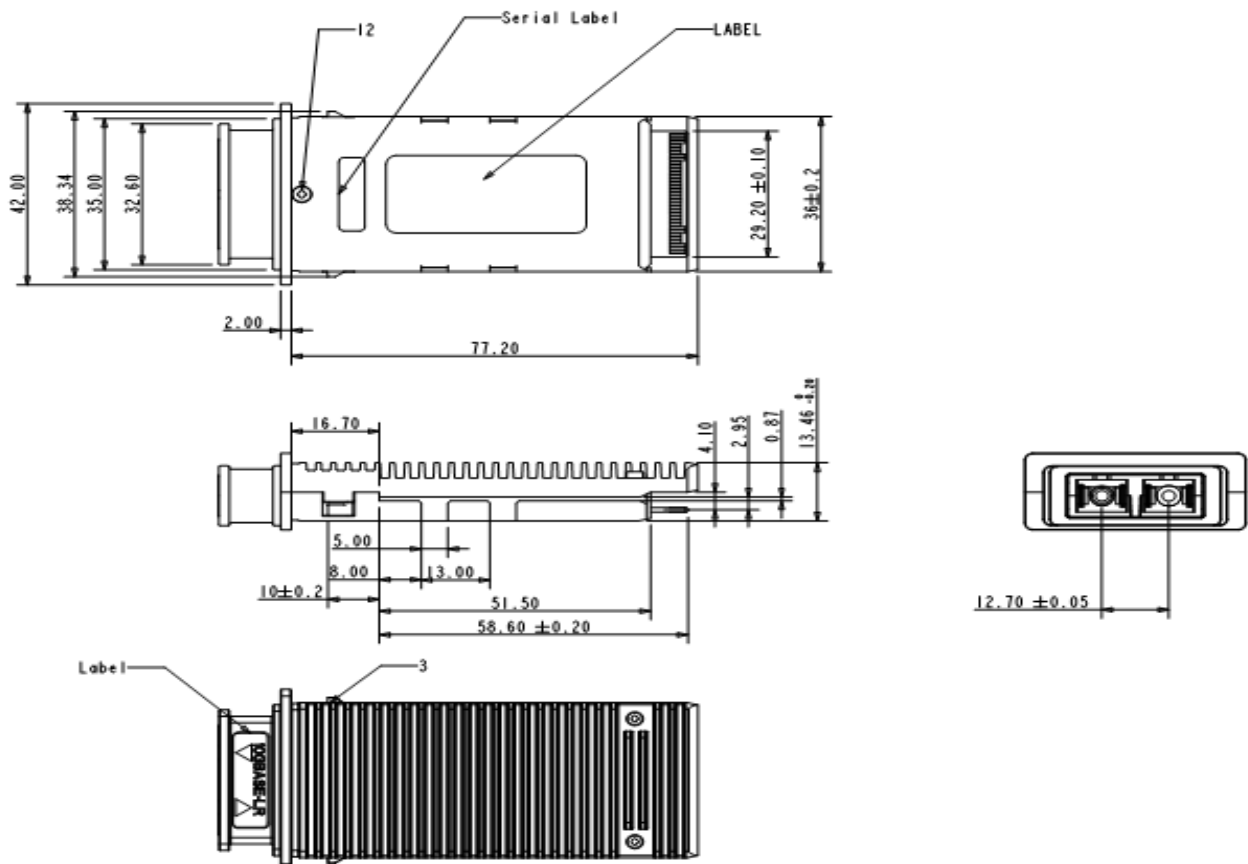

Figure2. Functional Diagram of Typical X2 Style Transceiver



Dimensions in mm

Figure3. Mechanical Dimensions

Ordering information

Part Number	Product Description
X2-10GB-ZR	1550nm, 10.3125Gbps, 80Km, 0°C ~ +70°C

TINOUT TECHNOLOGY LIMITED

E-mail: CROFT@TINOUT.com <http://www.TINOUT.com>