



**Features:**

- F Compliant with Specifications for IEEE802.3Z
- F Multi-Source Package with Duplex LC Connector
- F Up to 1.25Gb/s Data Links
- F Single Mode 1310nm FP-LD
- F Single +3.3V Power Supply
- F Hot-Pluggable
- F Compliant with Bellcore TA-NWT-000983
- F Eye Safety Designed to Meet Laser Class1, Compliant with IEC60825-1
- F RoHS Compliant Products Available

**Applications:**

- F Gigabit Ethernet
- F 1x Fiber Channel
- F Switch to Switch Interface
- F Switched Backplane Applications
- F Router/Server Interface
- F Other Optical Links

**Specification:**

**I Electrical and Optical Characteristics: (Condition: T<sub>a</sub>=T<sub>OP</sub>)**

Parameter	Symbol	Min.	Typical	Max.	Unit
Transmitter Differential Input Volt	+/-TX_DAT	200		2400	mV p-p
Supply Current	I <sub>CC</sub>		130	180	mA
Tx_Disable Input Voltage – Low	V <sub>IL</sub>	0		0.8	V
Tx_Disable Input Voltage – High	V <sub>IH</sub>	2.0		V <sub>cc</sub>	V
Tx_Fault Output Voltage – Low	V <sub>OL</sub>	0		0.8	V
Tx_Fault Output Voltage – High	V <sub>OH</sub>	2.0		V <sub>cc</sub>	V
Receiver Differential Output Volt	+/-RX_DAT	600		1400	mV p-p
Rx_LOS Output Voltage- Low	V <sub>OL</sub>	0		0.8	V
Rx_LOS Output Voltage- High	V <sub>OH</sub>	2.0		V <sub>cc</sub>	V

**Transmitter Section:**

Parameter	Symbol	Min.	Typical	Max.	Unit
Data Rate	B	-	1250	-	Mb/s
Centre Wavelength	λ <sub>c</sub>	1290	1310	1330	nm
Output Spectral Width	Δλ	-	-	4	nm
Average Output Power	P <sub>o</sub>	-9.5	-	-3	dBm
Extinction Ratio	EXT	9	-	-	dB
Data Input Voltage-High	V <sub>IHS</sub>	V <sub>cc</sub> -1.16	-	V <sub>cc</sub> -0.89	V
Data Input Voltage -Low	V <sub>ILS</sub>	V <sub>cc</sub> -1.82	-	V <sub>cc</sub> -1.48	V
Supply Current	I <sub>CC</sub>	-	90	150	mA
Output Optical Eye	Compliant with IEEE802.3Z				

**1.25Gb/s SFP Optical Transceiver with DDMI (PTP8632D-3)  
Hot Pluggable, Duplex LC, +3.3V, 1310nm, FP-LD, Single-Mode**



**Receiver Section:**

Parameter	Symbol	Min.	Typical	Max.	Unit
Receive Sensitivity	$P_{min}$	-	-	-22	dBm
Maximum Input Power	$P_{MAX}$	-3	-	-	dBm
Signal Detect Threshold-Assertion:	$SD_{HIGH}$	-	-	-23	dBm
Signal Detect Threshold-Deassertion:	$SD_{LOW}$	-33	-	-	dBm
Hysteresis	-	-	2.0	-	dBm
Output High Voltage	$V_{OH}$	$V_{cc}-1.03$	-	$V_{cc}-0.89$	V
Output Low Voltage	$V_{OL}$	$V_{cc}-1.82$	-	$V_{cc}-1.63$	V
Operating Wavelength	$\lambda_c$	1100	-	1600	nm
Supply Current	$I_{CC}$	-	80	110	mA

**I Absolute Maximum Ratings: ( $T_C=25^\circ C$ )**

Parameter	Symbol	Min.	Max.	Unit
Storage Temperature	$T_{ST}$	-40	+85	$^\circ C$
Operating Temperature	$T_{IP}$	0	+70	$^\circ C$
Input Voltage	$T_{CC}$	0	+5	V

**I Recommended Operating Environment:**

Parameter	Symbol	Min.	Typical	Max.	Unit
Supply Voltage	$V_{CC}$	+3.0	+3.3	+3.6	V
Operating Temperature	$T_{OP}$	0	-	+70	$^\circ C$

**I Timing Characteristics:**

Parameter	Symbol	Min.	Typical	Max.	Unit
TX_DISABLE Assert Time	$t_{off}$		3	10	usec
TX_DISABLE Negate Time	$t_{on}$		0.5	1	msec
Time to initialize include reset of TX_FAULT	$t_{int}$		30	300	msec
TX_FAULT from fault to assertion	$t_{fault}$		20	100	usec
TX_DISBEL time to start reset	$t_{reset}$	10			usec
Receiver Loss of Signal Assert Time (off to On)	$T_{A,RX\_LOS}$			100	usec
Receiver Loss of Signal Assert Time (on to off)	$T_{d,RX\_LOS}$			100	usec

**I Digital Diagnostic Monitor Characteristics:**

Parameter	Min.	Unit
Tx Output Power Accuracy	$\pm 3.0$	dBm
Rx Input Power Accuracy	$\pm 3.0$	dBm
Laser Bias Current Accuracy	$\pm 10$	%



Transceiver Internal Temperature Accuracy	±3.0	° C
Transceiver Internal Supply Voltage Accuracy	±0.1	V

### I Serial ID Memory Contents:

Data Address	Length (Byte)	Name of Length	Description and Contents
<b>Base ID Fields</b>			
0	1	Identifier	Type of Serial transceiver (03h=SFP)
1	1	Reserved	Extended identifier of type serial transceiver (04h)
2	1	Connector	Code of optical connector type (07=LC)
3-10	8	Transceiver	Gigabit Ethernet 1000Base-SX & Fiber Channel
11	1	Encoding	8B10B (01h)
12	1	BR,Nominal	Nominal baud rate, unit of 100Mbps
13-14	2	Reserved	(0000h)
15	1	Length(9um)	Link length supported for 9/125um fiber, units of 100m
16	1	Length(50um)	Link length supported for 50/125um fiber, units of 10m
17	1	Length(62.5um)	Link length supported for 62.5/125um fiber, units of 10m
18	1	Length(Copper)	Link length supported for copper, units of meters
19	1	Reserved	
20-35	16	Vendor Name	SFP vendor name: TINOUT
36	1	Reserved	
37-39	3	Vendor OUI	SFP transceiver vendor OUI ID
40-55	16	Vendor PN	Part Number: "PTPxxxxxx" (ASCII)
56-59	4	Vendor rev	Revision level for part number
60-62	3	Reserved	
63	1	CCID	Least significant byte of sum of data in address 0-62
<b>Extended ID Fields</b>			
64-65	2	Option	Indicates which optical SFP signals are implemented (001Ah = LOS, TX_FAULT, TX_DISABLE all supported)
66	1	BR, max	Upper bit rate margin, units of %
67	1	BR, min	Lower bit rate margin, units of %
68-83	16	Vendor SN	Serial number (ASCII)
84-91	8	Date code	TINOUT's Manufacturing date code
92-94	3	Reserved	
95	1	CCEX	Check code for the extended ID Fields (addresses 64 to 94)
<b>Vendor Specific ID Fields</b>			
96-127	32	Readable	TINOUT specific date, read only

### I Serial ID Memory Contents: (A2H)

Address	# Bytes	Name	Description
00-01	2	Temp High Alarm	MSB at low address
02-03	2	Temp Low Alarm	MSB at low address
04-05	2	Temp High Warning	MSB at low address
06-07	2	Temp Low Warning	MSB at low address
08-09	2	Voltage High Alarm	MSB at low address



10-11	2	Voltage Low Alarm	MSB at low address
12-13	2	Voltage High Warning	MSB at low address
14-15	2	Voltage Low Warning	MSB at low address
16-17	2	Bias High Alarm	MSB at low address
18-19	2	Bias Low Alarm	MSB at low address
20-21	2	Bias High Warning	MSB at low address
22-23	2	Bias Low Warning	MSB at low address
24-25	2	TX Power High Alarm	MSB at low address
26-27	2	TX Power Low Alarm	MSB at low address
28-29	2	TX Power High Warning	MSB at low address
30-31	2	TX Power Low Warning	MSB at low address
32-33	2	RX Power High Alarm	MSB at low address
34-35	2	RX Power Low Alarm	MSB at low address
36-37	2	RX Power High Warning	MSB at low address
38-39	2	RX Power Low Warning	MSB at low address
40-55	16	Reserved	Reserved for future monitored quantities

Address	# Bytes	Name	Description
56-59	4	Rx_PWR(4)	Single precision floating point calibration data - Rx optical power. Bit 7 of byte 56 is MSB. Bit 0 of byte 59 is LSB.
60-63	4	Rx_PWR(3)	Single precision floating point calibration data - Rx optical power. Bit 7 of byte 60 is MSB. Bit 0 of byte 63 is LSB.
64-67	4	Rx_PWR(2)	Single precision floating point calibration data - Rx optical power. Bit 7 of byte 64 is MSB, bit 0 of byte 67 is LSB.
68-71	4	Rx_PWR(1)	Single precision floating point calibration data - Rx optical power. Bit 7 of byte 68 is MSB, bit 0 of byte 71 is LSB.
72-75	4	Rx_PWR(0)	Single precision floating point calibration data - Rx optical power. Bit 7 of byte 72 is MSB, bit 0 of byte 75 is LSB.
76-77	2	Tx_I(Slope)	Fixed decimal (unsigned) calibration data, laser bias current. Bit 7 of byte 76 is MSB, bit 0 of byte 77 is LSB.
78-79	2	Tx_I(Offset)	Fixed decimal (signed two's complement) calibration data, laser bias current. Bit 7 of byte 78 is MSB, bit 0 of byte 79 is LSB
80-81	2	Tx_PWR(Slope)	Fixed decimal (unsigned) calibration data, transmittercoupled output power. Bit 7 of byte 80 is MSB, bit 0 of byte81 is LSB.
82-83	2	Tx_PWR(Offset)	Fixed decimal (signed two's complement) calibration data, transmitter coupled output power. Bit 7 of byte 82 is MSB, bit 0 of byte 83 is LSB.
84-85	2	T(Slope)	Fixed decimal (unsigned) calibration data, internal module temperature. Bit 7 of byte 84 is MSB, bit 0 of byte 85 is LSB.
86-87	2	T(Offset)	Fixed decimal (signed two's complement) calibration data, internal module temperature. Bit 7 of byte 86 is MSB, bit 0 of byte 87 is LSB.



88-89	2	V(Slope)	Fixed decimal (unsigned) calibration data, internal module supply voltage. Bit 7 of byte 88 is MSB, bit 0 of byte 89 is LSB.
90-91	2	V(Offset)	Fixed decimal (signed two's complement) calibration data, internal module supply voltage. Bit 7 of byte 90 is MSB. Bit 0 of byte 91 is LSB.
92-95	4	Reserved	Reserved

Byte	Bit	Name	Description
<b>Converted analog values. Calibrated 16 bit data</b>			
96	All	Temperature MSB	Internally measured module temperature.
97	All	Temperature LSB	
98	All	Vcc MSB	Internally measured supply voltage in transceiver.
99	All	Vcc LSB	
100	All	TX Bias MSB	Internally measured TX Bias Current.
101	All	TX Bias LSB	
102	All	TX Power MSB	Measured TX output power.
103	All	TX Power LSB	
104	All	RX Power MSB	Measured RX input power.
105	All	RX Power LSB	
106	All	Reserved MSB	Reserved for 1st future definition of digitized analog input
107	All	Reserved LSB	Reserved for 1st future definition of digitized analog input
108	All	Reserved MSB	Reserved for 2nd future definition of digitized analog input
109	All	Reserved LSB	Reserved for 2nd future definition of digitized analog input
<b>Optional Status/Control Bits</b>			
110	7	TX Disable State	Digital state of the TX Disable Input Pin. Not supported.
110	6	Soft TX Disable	Read/write bit that allows software disable of laser. Not supported.
110	5	Reserved	
110	4	RX Rate Select State	Digital state of the SFP RX Rate Select Input Pin. Not supported.
110	3	Soft RX Rate Select	Read/write bit that allows software RX rate select. Not supported.
110	2	TX Fault	Digital state of the TX Fault Output Pin.
110	1	LOS	Digital state of the LOS Output Pin.
110	0	Data Ready	Indicates transceiver has achieved power up and data is ready
111	7-0	Reserved	Reserved.

Byte	Bit	Name	Description
<b>Reserved Optional Alarm and Warning Flag Bits</b>			
112	7	Temp High Alarm	Set when internal temperature exceeds high alarm level.
112	6	Temp Low Alarm	Set when internal temperature is below low alarm level.
112	5	Vcc High Alarm	Set when internal supply voltage exceeds high alarm level.
112	4	Vcc Low Alarm	Set when internal supply voltage is below low alarm level.
112	3	TX Bias High Alarm	Set when TX Bias current exceeds high alarm level.
112	2	TX Bias Low Alarm	Set when TX Bias current is below low alarm level.

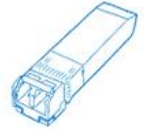

112	1	TX Power High Alarm	Set when TX output power exceeds high alarm level.
112	0	TX Power Low Alarm	Set when TX output power is below low alarm level.
113	7	RX Power High Alarm	Set when Received Power exceeds high alarm level.
113	6	RX Power Low Alarm	Set when Received Power is below low alarm level.
113	5	Reserved Alarm	
113	4	Reserved Alarm	
113	3	Reserved Alarm	
113	2	Reserved Alarm	
113	1	Reserved Alarm	
113	0	Reserved Alarm	
114	All	Reserved	
115	All	Reserved	
116	7	Temp High Warning	Set when internal temperature exceeds high warning level.
116	6	Temp Low Warning	Set when internal temperature is below low warning level.
116	5	Vcc High Warning	Set when internal supply voltage exceeds high warning level.
116	4	Vcc Low Warning	Set when internal supply voltage is below low warning level.
116	3	TX Bias High Warning	Set when TX Bias current exceeds high warning level.
116	2	TX Bias Low Warning	Set when TX Bias current is below low warning level.
116	1	TX Power High Warning	Set when TX output power exceeds high warning level.
116	0	TX Power Low Warning	Set when TX output power is below low warning level.
117	7	RX Power High Warning	Set when Received Power exceeds high warning level.
117	6	RX Power Low Warning	Set when Received Power is below low warning level.
117	5	Reserved Warning	
117	4	Reserved Warning	
117	3	Reserved Warning	
117	2	Reserved Warning	
117	1	Reserved Warning	
117	0	Reserved Warning	
118	All	Reserved	
119	All	Reserved	

Byte	# Byte	Name	Description
120-127	8	Vendor Specific	00h.
128-255	128		Writable Memory

## Block Diagram of Transceiver:

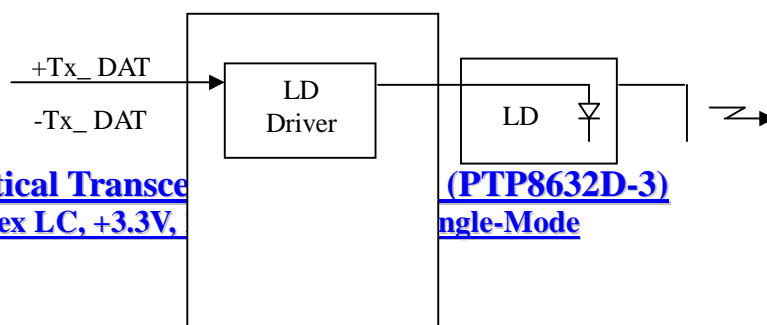

[1.25Gb/s SFP Optical Transceiver](#)  
[Hot Pluggable, Duplex LC, +3.3V,](#)

[\(PTP8632D-3\)](#)  
[Single-Mode](#)

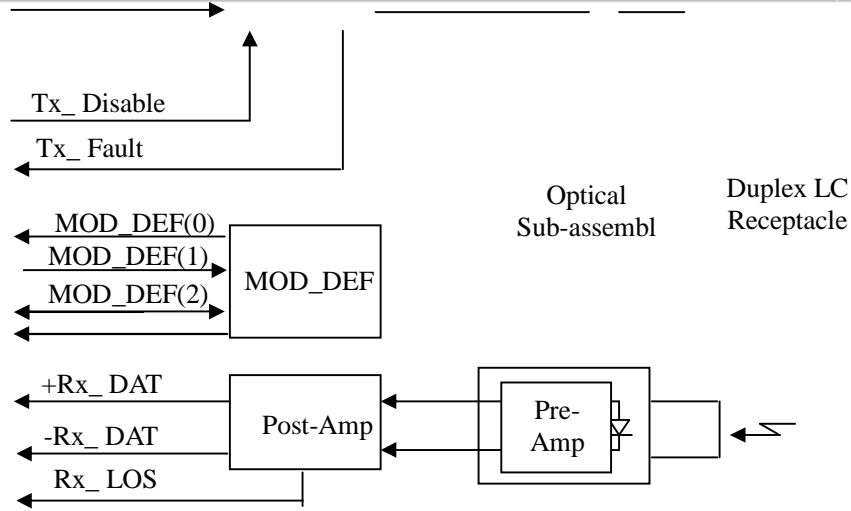

**Pin Assignment:**

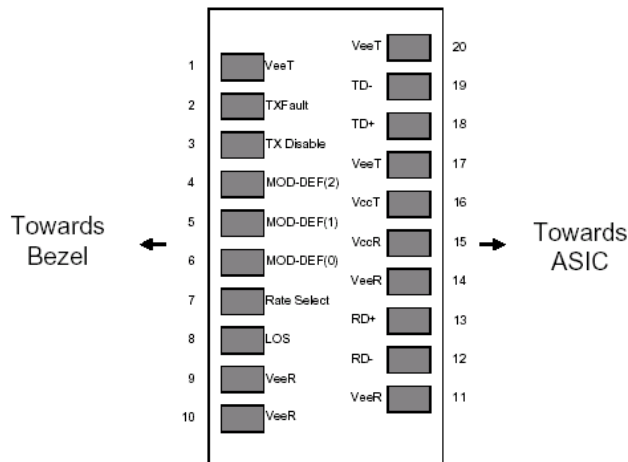

**Pin out of Connector Block on Host Board**

**Pin Description:**

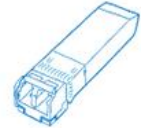

Pin	Symbol	Name/Description	Ref.
1	V <sub>EET</sub>	Transmitter Ground (Common with Receiver Ground)	1
2	T <sub>FAULT</sub>	Transmitter Fault. Not supported.	
3	T <sub>DIS</sub>	Transmitter Disable. Laser output disabled on high or open.	2
4	MOD_DEF(2)	Module Definition 2. Data line for Serial ID.	3
5	MOD_DEF(1)	Module Definition 1. Clock line for Serial ID.	3
6	MOD_DEF(0)	Module Definition 0. Grounded within the module.	3
7	Rate Select	No connection required	
8	LOS	Loss of Signal indication. Logic 0 indicates normal operation.	4
9	V <sub>EER</sub>	Receiver Ground (Common with Transmitter Ground)	1
10	V <sub>EER</sub>	Receiver Ground (Common with Transmitter Ground)	1
11	V <sub>EER</sub>	Receiver Ground (Common with Transmitter Ground)	1
12	RD-	Receiver Inverted DATA out. AC Coupled	
13	RD+	Receiver Non-inverted DATA out. AC Coupled	
14	V <sub>EER</sub>	Receiver Ground (Common with Transmitter Ground)	1
15	V <sub>CCR</sub>	Receiver Power Supply	
16	V <sub>CCT</sub>	Transmitter Power Supply	
17	V <sub>EET</sub>	Transmitter Ground (Common with Receiver Ground)	1
18	TD+	Transmitter Non-Inverted DATA in. AC Coupled.	
19	TD-	Transmitter Inverted DATA in. AC Coupled.	
20	V <sub>EET</sub>	Transmitter Ground (Common with Receiver Ground)	1

**Notes:**

1. Circuit ground is internally isolated from chassis ground.
2. Laser output disabled on TDIS >2.0V or open, enabled on TDIS <0.8V.
3. Should be pulled up with 4.7k – 10kohms on host board to a voltage between 2.0V and 3.6V. MOD\_DEF(0) pulls line low to indicate module is plugged in.
4. LOS is open collector output. Should be pulled up with 4.7k – 10kohms on host board to a voltage between 2.0V and 3.6V. Logic 0 indicates normal operation; logic 1 indicates loss of signal.

**Ordering information:**

Part Number	Product Description
PTP8632-3	1310nm, 1250Mbps, LC, 20km, 0°C~+70°C
PTP8632D-3	1310nm, 1250Mbps, LC, 20km, 0°C~+70°C, With Digital Diagnostic Monitoring
PTP8632-3I	1310nm, 1250Mbps, LC, 20km, -40°C~+85°C
PTP8632D-3I	1310nm, 1250Mbps, LC, 20km, -40°C~+85°C, With Digital Diagnostic Monitoring

**Mechanical Dimensions:**

[1.25Gb/s SFP Optical Transceiver with DDMI \(PTP8632D-3\) Hot Pluggable, Duplex LC, +3.3V, 1310nm, FP-LD, Single-Mode](#)



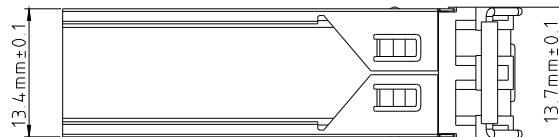
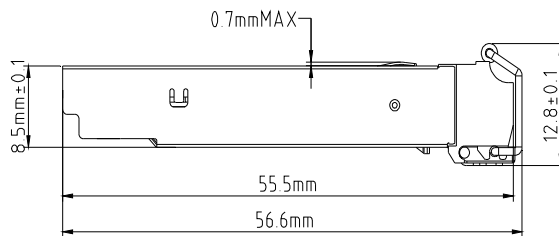
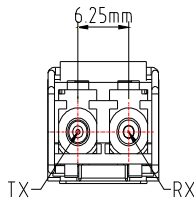
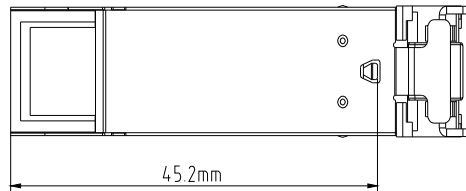
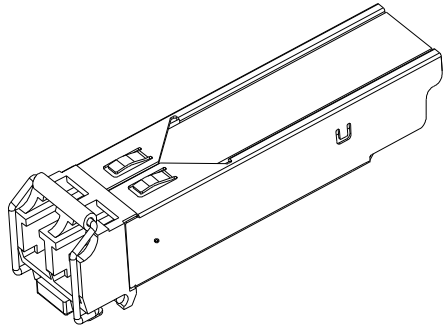
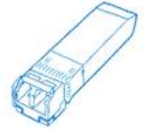

**Recommended Circuit:**

**[1.25Gb/s SFP Optical Transceiver with DDMI \(PTP8632D-3\)](#)**  
**[Hot Pluggable, Duplex LC, +3.3V, 1310nm, FP-LD, Single-Mode](#)**

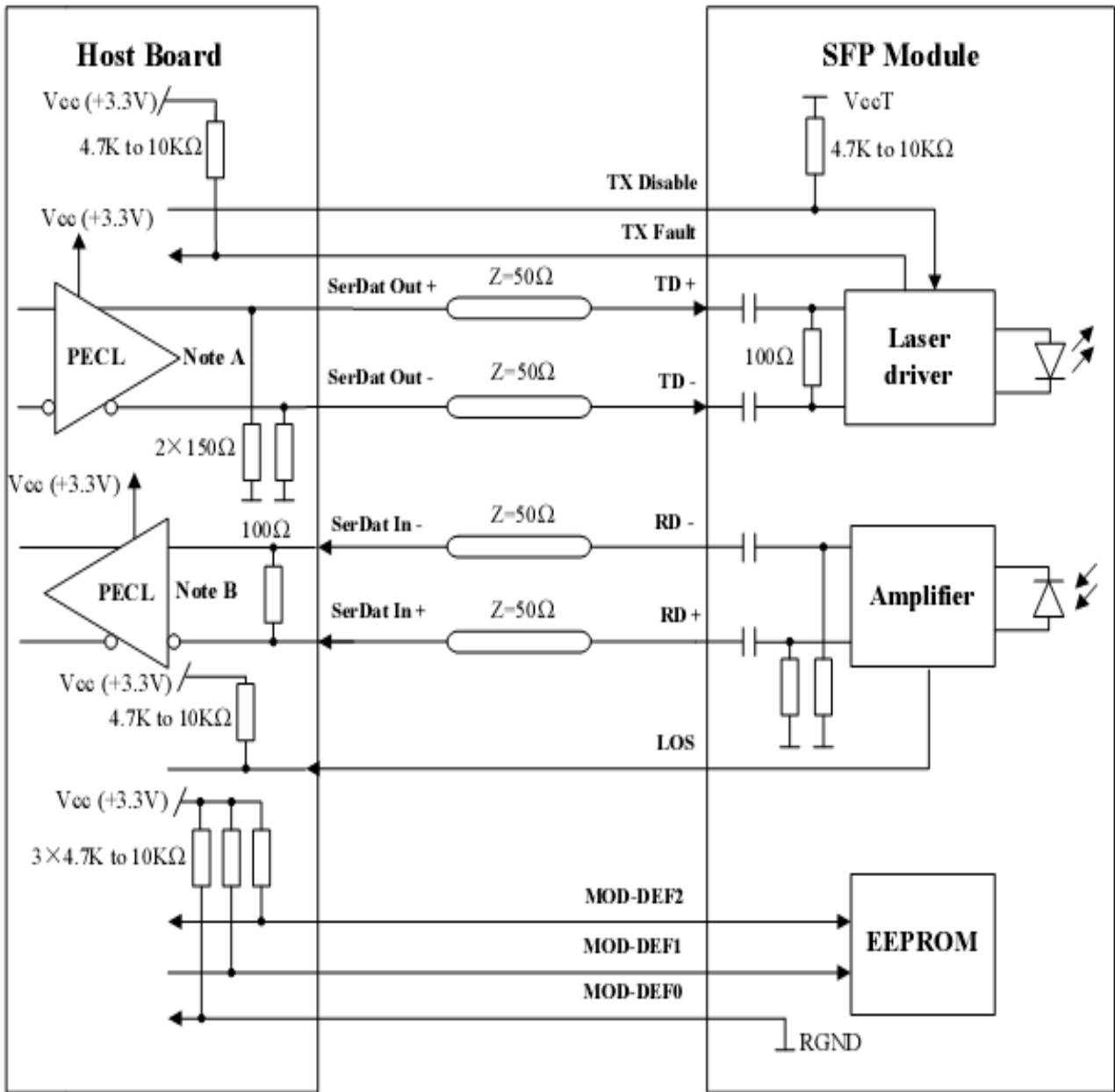

Note A: Circuit assumes open emitter output

Note B: Circuit assumes high impedance internal bias @ Vcc-1.3V