



**Features:**

- F Compliant with ITU-T G.957,G.958
- F Multi-Source Package with Duplex LC Connector
- F Up to 155Mb/s Data Rate
- F 1550nm DFB Single-Mode
- F Single +3.3V Power Supply
- F Hot-Pluggable
- F Eye Safety Designed to Meet Laser Class1, Compliant with IEC60825-1
- F RoHS Compliant Products Available

**Applications:**

- F SONET OC-3/SDH STM-1
- F Fast Ethernet
- F Other Optical Links

**Specification:**

**I Electrical and Optical Characteristics: (Condition: T<sub>a</sub>=T<sub>OP</sub>)**

Parameter	Symbol	Min.	Typical	Max.	Unit
Transmitter Differential Input Voltage	+/-TX_DAT	200		1600	mV p-p
Supply Current	I <sub>CC</sub>		200	250	mA
Tx_Disable Input Voltage – Low	V <sub>IL</sub>	0		0.8	V
Tx_Disable Input Voltage – High	V <sub>IH</sub>	2.0		V <sub>cc</sub>	V
Tx_Fault Output Voltage – Low	V <sub>OL</sub>	0		0.8	V
Tx_Fault Output Voltage – High	V <sub>OH</sub>	2.0		V <sub>cc</sub>	V
Receiver Differential Output Voltage	+/-RX_DAT	400		1400	mV p-p
Rx_LOS Output Voltage- Low	V <sub>OL</sub>	0		0.8	V
Rx_LOS Output Voltage- High	V <sub>OH</sub>	2.0		V <sub>cc</sub>	V

**Transmitter**

Parameter	Symbol	Min.	Typical	Max.	Unit
Data Rate	B	-	155	-	Mb/s
Centre Wavelength	λ <sub>c</sub>	1480	1550	1580	nm
Output Spectral Width	Δλ	-	-	1	nm
Average Output Power	P <sub>o</sub>	-2	-	0	dBm
Extinction Ratio	EXT	10	-	-	dB
Data Input Voltage-High	V <sub>IHS</sub>	V <sub>cc</sub> -1.16	-	V <sub>cc</sub> -0.89	V
Data Input Voltage -Low	V <sub>ILS</sub>	V <sub>cc</sub> -1.82	-	V <sub>cc</sub> -1.48	V
Supply Current	I <sub>CC</sub>	-	90	110	mA
Output Optical Eye	Compliant with ITU-T G.957				

**Receiver**



Parameter	Symbol	Min.	Typical	Max.	Unit
Receive Sensitivity	$P_{min}$	-	-	-36	dBm
Maximum Input Power	$P_{MAX}$	-3	-	-	dBm
Signal Detection-Asserted	$P_{H-L}$	-47	-		dBm
Signal Detection-Deserted	$P_{L-H}$		-	-37	dBm
Output High Voltage	$V_{OH}$	$V_{cc}-1.03$	-	$V_{cc}-0.89$	V
Output Low Voltage	$V_{OL}$	$V_{cc}-1.82$	-	$V_{cc}-1.63$	V
Operating Wavelength	$\lambda_c$	1100	-	1600	nm
Supply Current	$I_{CC}$	-	80	110	mA

### I Absolute Maximum Ratings: ( $T_C=25^{\circ}C$ )

Parameter	Symbol	Min.	Max.	Unit
Storage Temperature	$T_{ST}$	-40	+85	$^{\circ}C$
Operating Temperature	$T_{IP}$	0	+70	$^{\circ}C$
Input Voltage	$T_{CC}$	0	+5	V

### I Recommended Operating Environment:

Parameter	Symbol	Min.	Typical	Max.	Unit
Supply Voltage	$V_{CC}$	+3.0	+3.3	+3.6	V
Operating Temperature	$T_{OP}$	0	-	+70	$^{\circ}C$

### I Timing Characteristics:

Parameter	Symbol	Min.	Typical	Max.	Unit
TX_DISABLE Assert Time	$t_{off}$		3	10	usec
TX_DISABLE Negate Time	$t_{on}$		0.5	1	msec
Time to Initialize Include Reset of TX_FAULT	$t_{int}$		30	300	msec
TX_FAULT from Fault to Assertion	$t_{fault}$		20	100	usec
TX_DISBEL Time to Start Reset	$t_{reset}$	10			usec
Receiver Loss of Signal Assert Time (Off to On)	$T_{A,RX\_LOS}$			100	usec
Receiver Loss of Signal Assert Time (On to Off)	$T_{d,RX\_LOS}$			100	usec

### Serial ID Memory Contents:

Data	Length	Name of	Description and Contents
------	--------	---------	--------------------------

[155Mb/s SFP Optical Transceiver without DDMI \(PTP825D80-3\)  
Hot Pluggable, Duplex LC, +3.3V, 1550nm, DFB-LD, Single-Mode](#)



Address	(Byte)	Length	
<b>Base ID Fields</b>			
0	1	Identifier	Type of Serial transceiver (03h=SFP)
1	1	Reserved	Extended identifier of type serial transceiver (04h)
2	1	Connector	Code of optical connector type (07=LC)
3-10	8	Transceiver	Gigabit Ethernet 1000Base-SX & Fiber Channel
11	1	Encoding	8B10B (01h)
12	1	BR,Nominal	Nominal baud rate, unit of 100Mbps
13-14	2	Reserved	(0000h)
15	1	Length(9um)	Link length supported for 9/125um fiber, units of 100m
16	1	Length(50um)	Link length supported for 50/125um fiber, units of 10m
17	1	Length(62.5um)	Link length supported for 62.5/125um fiber, units of 10m
18	1	Length(Copper)	Link length supported for copper, units of meters
19	1	Reserved	
20-35	16	Vendor Name	SFP vendor name: TINOUT
36	1	Reserved	
37-39	3	Vendor OUI	SFP transceiver vendor OUI ID
40-55	16	Vendor PN	Part Number: "PTPxxxxxx" (ASCII)
56-59	4	Vendor rev	Revision level for part number
60-62	3	Reserved	
63	1	CCID	Least significant byte of sum of data in address 0-62
<b>Extended ID Fields</b>			
64-65	2	Option	Indicates which optical SFP signals are implemented (001Ah = LOS, TX_FAULT, TX_DISABLE all supported)
66	1	BR, max	Upper bit rate margin, units of %
67	1	BR, min	Lower bit rate margin, units of %
68-83	16	Vendor SN	Serial number (ASCII)
84-91	8	Date code	TINOUT 's Manufacturing date code
92-94	3	Reserved	
95	1	CCEX	Check code for the extended ID Fields (addresses 64 to 94)
<b>Vendor Specific ID Fields</b>			
96-127	32	Readable	TINOUT specific date, read only

**Block Diagram of Transceiver:**

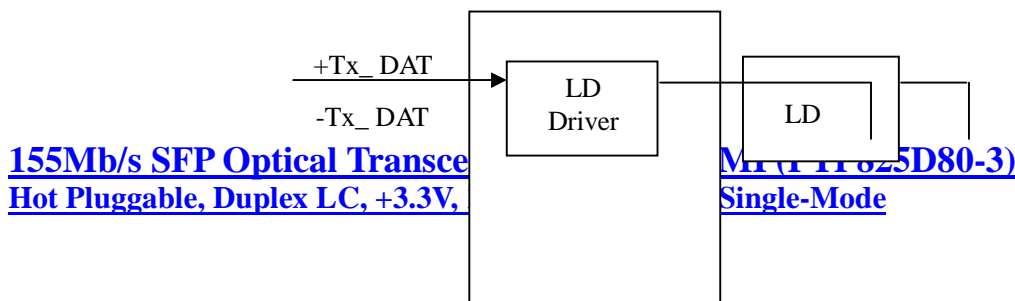

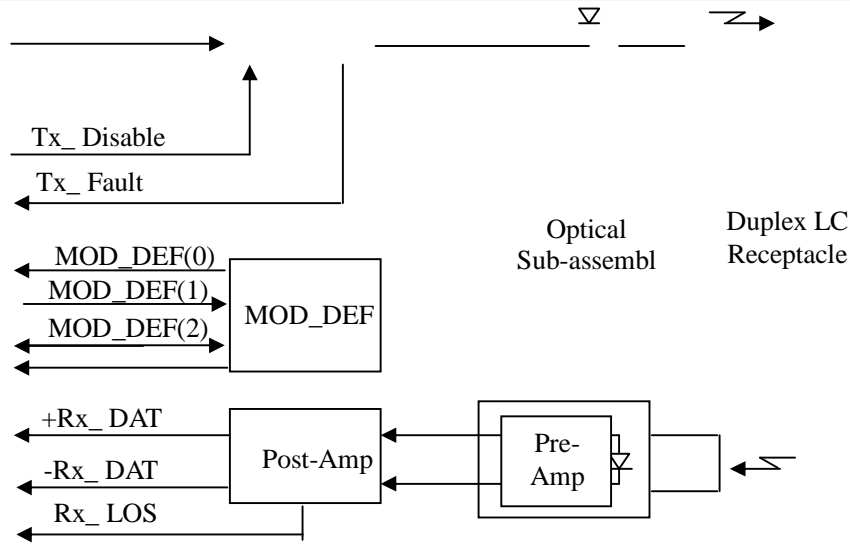
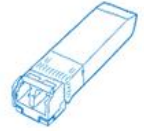

**Pin Assignment:**

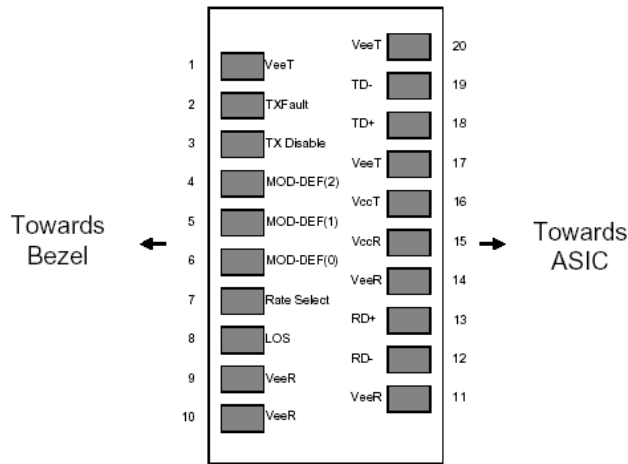

**Pin out of Connector Block on Host Board**

**Pin Description:**



Pin	Symbol	Name/Description	Ref.
1	V <sub>EET</sub>	Transmitter Ground (Common with Receiver Ground)	1
2	T <sub>FAULT</sub>	Transmitter Fault. Not supported.	
3	T <sub>DIS</sub>	Transmitter Disable. Laser output disabled on high or open.	2
4	MOD_DEF(2)	Module Definition 2. Data line for Serial ID.	3
5	MOD_DEF(1)	Module Definition 1. Clock line for Serial ID.	3
6	MOD_DEF(0)	Module Definition 0. Grounded within the module.	3
7	Rate Select	No connection required	
8	LOS	Loss of Signal indication. Logic 0 indicates normal operation.	4
9	V <sub>EER</sub>	Receiver Ground (Common with Transmitter Ground)	1
10	V <sub>EER</sub>	Receiver Ground (Common with Transmitter Ground)	1
11	V <sub>EER</sub>	Receiver Ground (Common with Transmitter Ground)	1
12	RD-	Receiver Inverted DATA out. AC Coupled	
13	RD+	Receiver Non-inverted DATA out. AC Coupled	
14	V <sub>EER</sub>	Receiver Ground (Common with Transmitter Ground)	1
15	V <sub>CCR</sub>	Receiver Power Supply	
16	V <sub>CCT</sub>	Transmitter Power Supply	
17	V <sub>EET</sub>	Transmitter Ground (Common with Receiver Ground)	1
18	TD+	Transmitter Non-Inverted DATA in. AC Coupled.	
19	TD-	Transmitter Inverted DATA in. AC Coupled.	
20	V <sub>EET</sub>	Transmitter Ground (Common with Receiver Ground)	1

**Notes:**

1. Circuit ground is internally isolated from chassis ground.
2. Laser output disabled on TDIS >2.0V or open, enabled on TDIS <0.8V.
3. Should be pulled up with 4.7k – 10kohms on host board to a voltage between 2.0V and 3.6V. MOD\_DEF(0) pulls line low to indicate module is plugged in.
4. LOS is open collector output. Should be pulled up with 4.7k – 10kohms on host board to a voltage between 2.0V and 3.6V. Logic 0 indicates normal operation; logic 1 indicates loss of signal.

**Ordering information:**

Part Number	Product Description
PTP825D80-3	1550nm, 155Mbps, LC, 80km, 0°C~+70°C
PTP825D80D-3	1550nm, 155Mbps, LC, 80km, 0°C~+70°C, With Digital Diagnostic Monitoring
PTP825D80-3I	1550nm, 155Mbps, LC, 80km, -40°C~+85°C
PTP825D80D-3I	1550nm, 155Mbps, LC, 80km, -40°C~+85°C, With Digital Diagnostic Monitoring

**Mechanical Dimensions:**

[155Mb/s SFP Optical Transceiver without DDMI \(PTP825D80-3\) Hot Pluggable, Duplex LC, +3.3V, 1550nm, DFB-LD, Single-Mode](#)

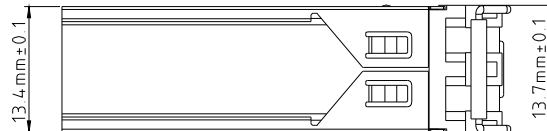
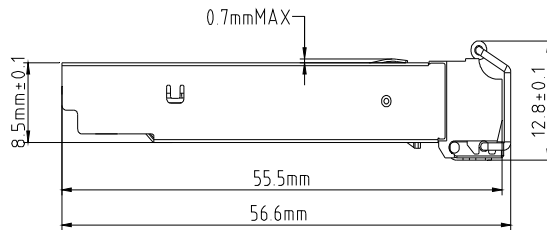
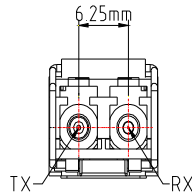
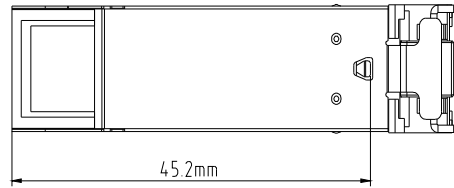
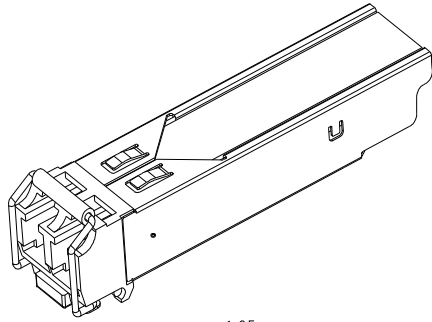
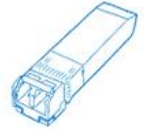

**Recommended Circuit:**

**[155Mb/s SFP Optical Transceiver without DDMI \(PTP825D80-3\)](#)**  
**[Hot Pluggable, Duplex LC, +3.3V, 1550nm, DFB-LD, Single-Mode](#)**

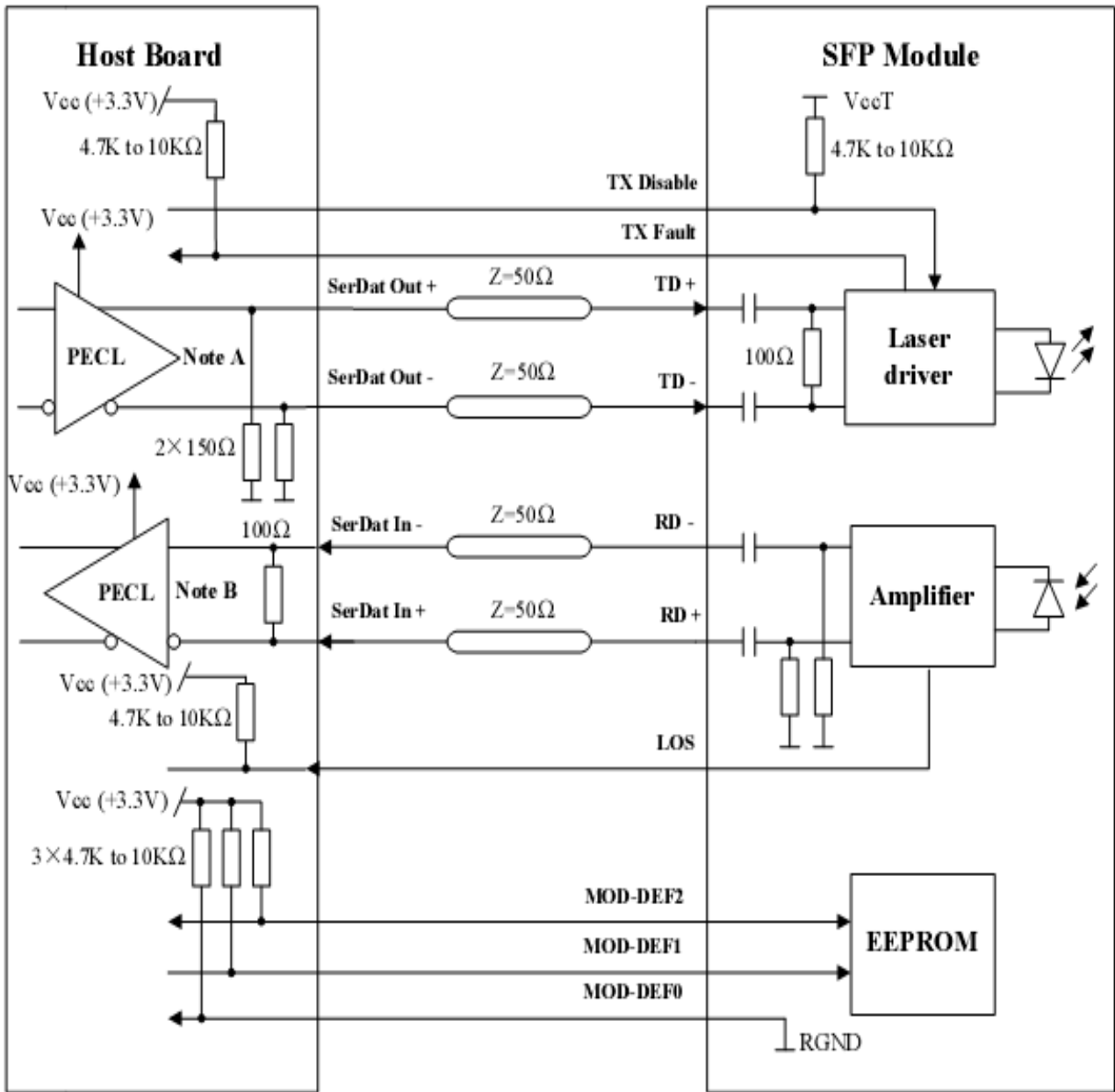
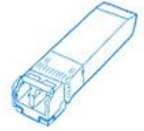

Note A: Circuit assumes open emitter output

Note B: Circuit assumes high impedance internal bias @Vcc-1.3V