

**Features:**

- F Fully Compliant with ITU-T G.957, G.958 Specification
- F Up to 2.5Gb/s Data Links
- F Multi-Source Package with Duplex LC Connector
- F Eye Safety Designed to Meet Laser Class1, Compliant with IEC60825-1
- F Single +3.3V Power Supply
- F Hot-Pluggable
- F Compliant with Bellcore TA-NWT-000983
- F RoHS Compliant Products Available

**Applications:**

- F SDH STM-16
- F SONET OC-48
- F 2x Fiber Channel
- F Other Optical Links

**Specification:**

**I Electrical and Optical Characteristics: (Condition:  $T_a=T_{OP}$ )**

Parameter	Symbol	Min.	Typical	Max.	Unit
Transmitter Differential Input Volt	+/-TX_DAT	200		2400	mV p-p
Supply Current	I <sub>CC</sub>		150	200	mA
Tx_Disable Input Voltage – Low	V <sub>IL</sub>	0		0.8	V
Tx_Disable Input Voltage – High	V <sub>IH</sub>	2.0		V <sub>cc</sub>	V
Tx_Fault Output Voltage – Low	V <sub>OL</sub>	0		0.8	V
Tx_Fault Output Voltage – High	V <sub>OH</sub>	2.0		V <sub>cc</sub>	V
Receiver Differential Output Volt	+/-RX_DAT	600		1400	mV p-p
Rx_LOS Output Voltage- Low	V <sub>OL</sub>	0		0.8	V
Rx_LOS Output Voltage- High	V <sub>OH</sub>	2.0		V <sub>cc</sub>	V

**Transmitter Section:**

Parameter	Symbol	Min.	Typical	Max.	Unit
Data Rate	B	-	2.5	-	Gb/s
Centre Wavelength	$\lambda_c$	1296	1310	1330	nm
Output Spectral Width	$\Delta \lambda$	-	-	1	nm
Average Output Power	P <sub>o</sub>	-5	-	0	dBm
Extinction Ratio	E.R.	8.2	-	-	dB
Rise and Fall Time (20~80%)	T <sub>r</sub>	-		0.15	ns
Data Input Voltage-High	V <sub>IHS</sub>	V <sub>cc</sub> -1.16	-	V <sub>cc</sub> -0.89	V
Data Input Voltage -Low	V <sub>ILS</sub>	V <sub>cc</sub> -1.82	-	V <sub>cc</sub> -1.48	V
Supply Current	I <sub>CC</sub>	-	90	120	mA
Output Optical Eye	Compliant with ITU-T G.957				

**[2.5Gb/s SFP Optical Transceiver without DDMI \(PTP883D2-3\)](#)  
[Hot Pluggable, Duplex LC, +3.3V, 1310nm, DFB-LD, Single-Mode](#)**



**Receiver Section:**

Parameter	Symbol	Min.	Typical	Max.	Unit
Date Rate	B	-	2.5	-	Gb/s
Receive Sensitivity	P <sub>min</sub>	-	-	-18	dBm
Maximum Input Power	P <sub>MAX</sub>	-3	-	-	dBm
Signal Detection-Asserted	P <sub>H-L</sub>	1100	-	1620	dBm
Signal Detect Threshold-Assertion:	SD <sub>HIGH</sub>			-20	dBm
Signal Detect Threshold-Deassertion:	SD <sub>LOW</sub>	-30			dBm
Hysteresis	-		2.0		dB
Supply Current	I <sub>CC</sub>	-	80	110	mA
Rise and Fall time (20~80%)	T <sub>r</sub> /T <sub>f</sub>			0.15	ns
Output High Voltage	V <sub>OH</sub>	V <sub>cc</sub> -1.03	-	V <sub>cc</sub> -0.89	V
Output Low Voltage	V <sub>OL</sub>	V <sub>cc</sub> -1.82	-	V <sub>cc</sub> -1.63	V
Alarm Output Interface	LVTTL				

**I Absolute Maximum Ratings:**

Parameter	Symbol	Min.	Max.	Unit
Storage Temperature	T <sub>ST</sub>	-40	+85	°C
Operating Temperature	T <sub>IP</sub>	0	+70	°C
Input Voltage	T <sub>CC</sub>	0	5	V

**I Recommended Operating Environment:**

Parameter	Symbol	Min.	Typical	Max.	Unit
Supply Voltage	V <sub>CC</sub>	+3.0	+3.3	+3.6	V
Operating Temperature	T <sub>OP</sub>	0	-	+70	°C

**I Timing Characteristics:**

Parameter	Symbol	Min.	Typical	Max.	Unit
TX_DISABLE Assert Time	t <sub>off</sub>		3	10	usec
TX_DISABLE Negate Time	t <sub>on</sub>		0.5	1	msec
Time to Initialize Include Reset of TX_FAULT	t <sub>int</sub>		30	300	msec
TX_FAULT from Fault to Assertion	t <sub>fault</sub>		20	100	usec
TX_DISBEL Time to Start Reset	t <sub>reset</sub>	10			usec
Receiver Loss of Signal Assert Time (Off to On)	T <sub>A</sub> ,RX_LOS			100	usec
Receiver Loss of Signal Assert Time (On to Off)	T <sub>d</sub> ,RX_LOS			100	usec

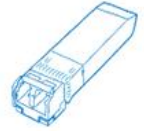

## I Serial ID Memory Contents:

Data Address	Length (Byte)	Name of Length	Description and Contents
<b>Base ID Fields</b>			
0	1	Identifier	Type of Serial transceiver (03h=SFP)
1	1	Reserved	Extended identifier of type serial transceiver (04h)
2	1	Connector	Code of optical connector type (07=LC)
3-10	8	Transceiver	Gigabit Ethernet 1000Base-SX & Fiber Channel
11	1	Encoding	8B10B (01h)
12	1	BR,Nominal	Nominal baud rate, unit of 100Mbps
13-14	2	Reserved	(0000h)
15	1	Length(9um)	Link length supported for 9/125um fiber, units of 100m
16	1	Length(50um)	Link length supported for 50/125um fiber, units of 10m
17	1	Length(62.5um)	Link length supported for 62.5/125um fiber, units of 10m
18	1	Length(Copper)	Link length supported for copper, units of meters
19	1	Reserved	
20-35	16	Vendor Name	SFP vendor name: TINOUT
36	1	Reserved	
37-39	3	Vendor OUI	SFP transceiver vendor OUI ID
40-55	16	Vendor PN	Part Number: "PTPxxxxxx" (ASCII)
56-59	4	Vendor rev	Revision level for part number
60-62	3	Reserved	
63	1	CCID	Least significant byte of sum of data in address 0-62
<b>Extended ID Fields</b>			
64-65	2	Option	Indicates which optical SFP signals are implemented (001Ah = LOS, TX_FAULT, TX_DISABLE all supported)
66	1	BR, max	Upper bit rate margin, units of %
67	1	BR, min	Lower bit rate margin, units of %
68-83	16	Vendor SN	Serial number (ASCII)
84-91	8	Date code	TINOUT's Manufacturing date code
92-94	3	Reserved	
95	1	CCEX	Check code for the extended ID Fields (addresses 64 to 94)
<b>Vendor Specific ID Fields</b>			
96-127	32	Readable	TINOUT specific date, read only

## Block Diagram of Transceiver:

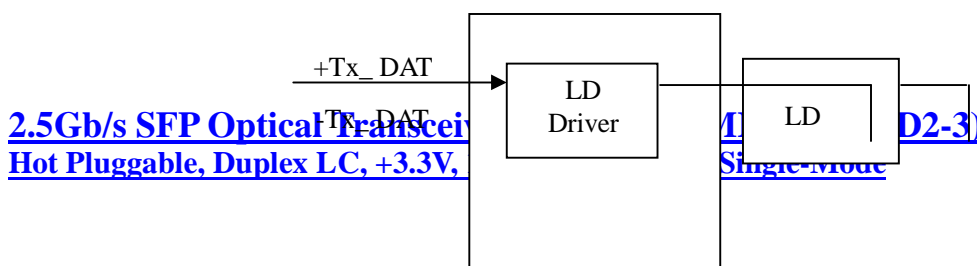

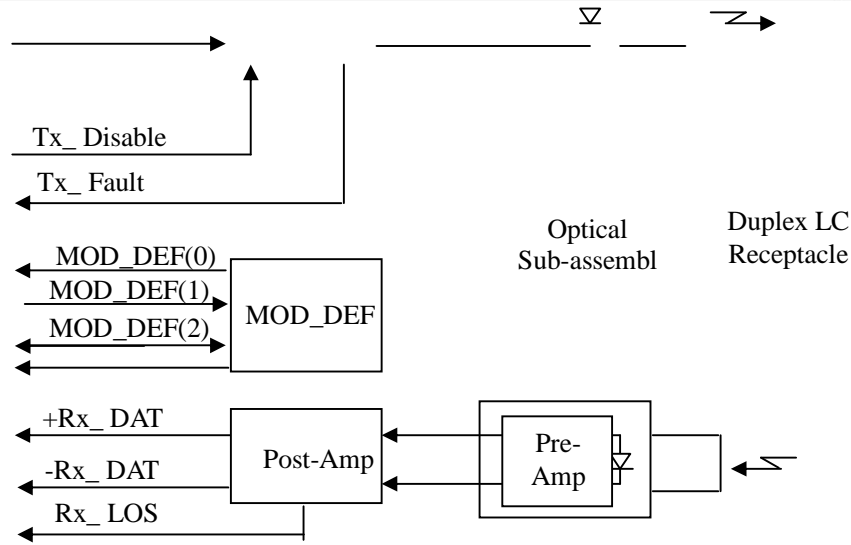
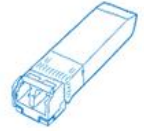

**Pin Assignment:**

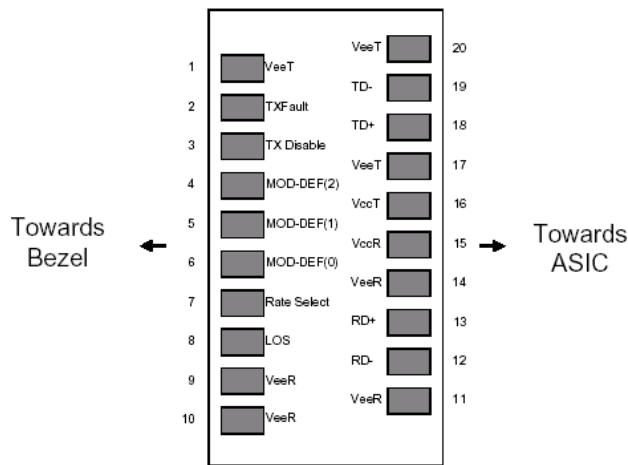

**Pin out of Connector Block on Host Board**

**Pin Description:**

**[2.5Gb/s SFP Optical Transceiver without DDMI \(PTP883D2-3\)](#)  
**[Hot Pluggable, Duplex LC, +3.3V, 1310nm, DFB-LD, Single-Mode](#)****



Pin	Symbol	Name/Description	Ref.
1	V <sub>EET</sub>	Transmitter Ground (Common with Receiver Ground)	1
2	T <sub>FAULT</sub>	Transmitter Fault. Not supported.	
3	T <sub>DIS</sub>	Transmitter Disable. Laser output disabled on high or open.	2
4	MOD_DEF(2)	Module Definition 2. Data line for Serial ID.	3
5	MOD_DEF(1)	Module Definition 1. Clock line for Serial ID.	3
6	MOD_DEF(0)	Module Definition 0. Grounded within the module.	3
7	Rate Select	No connection required	
8	LOS	Loss of Signal indication. Logic 0 indicates normal operation.	4
9	V <sub>EER</sub>	Receiver Ground (Common with Transmitter Ground)	1
10	V <sub>EER</sub>	Receiver Ground (Common with Transmitter Ground)	1
11	V <sub>EER</sub>	Receiver Ground (Common with Transmitter Ground)	1
12	RD-	Receiver Inverted DATA out. AC Coupled	
13	RD+	Receiver Non-inverted DATA out. AC Coupled	
14	V <sub>EER</sub>	Receiver Ground (Common with Transmitter Ground)	1
15	V <sub>CCR</sub>	Receiver Power Supply	
16	V <sub>CCT</sub>	Transmitter Power Supply	
17	V <sub>EET</sub>	Transmitter Ground (Common with Receiver Ground)	1
18	TD+	Transmitter Non-Inverted DATA in. AC Coupled.	
19	TD-	Transmitter Inverted DATA in. AC Coupled.	
20	V <sub>EET</sub>	Transmitter Ground (Common with Receiver Ground)	1

**Notes:**

1. Circuit ground is internally isolated from chassis ground.
2. Laser output disabled on TDIS >2.0V or open, enabled on TDIS <0.8V.
3. Should be pulled up with 4.7k – 10kohms on host board to a voltage between 2.0V and 3.6V. MOD\_DEF(0) pulls line low to indicate module is plugged in.
4. LOS is open collector output. Should be pulled up with 4.7k – 10kohms on host board to a voltage between 2.0V and 3.6V. Logic 0 indicates normal operation; logic 1 indicates loss of signal.

**Ordering information:**

Part Number	Product Description
PTP883D2-3	1310nm, 2.5G bps, LC, 20km, 0°C~+70°C
PTP883D2D-3	1310nm, 2.5G bps, LC, 20km, 0°C~+70°C, With Digital Diagnostic Monitoring
PTP883D2-3I	1310nm, 2.5G bps, LC, 20km, -40°C~+85°C
PTP883D2D-3I	1310nm, 2.5G bps, LC, 20km, -40°C~+85°C, With Digital Diagnostic Monitoring

**Mechanical Dimensions:**

[2.5Gb/s SFP Optical Transceiver without DDMI \(PTP883D2-3\)  
Hot Pluggable, Duplex LC, +3.3V, 1310nm, DFB-LD, Single-Mode](#)

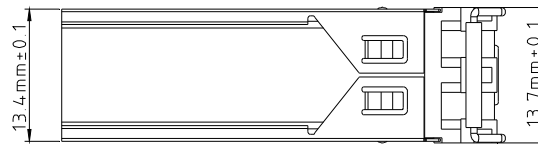
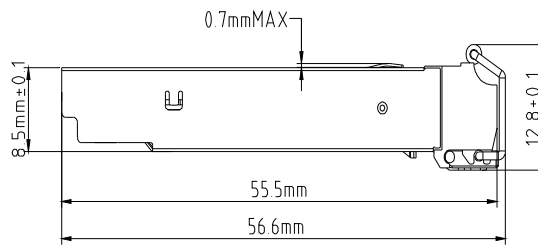
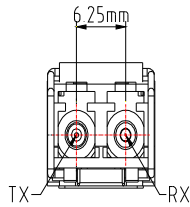
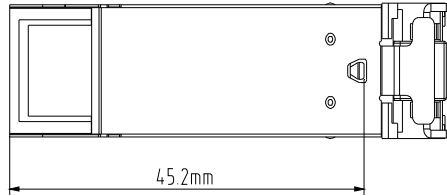
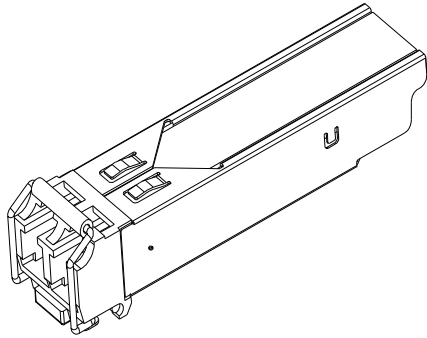
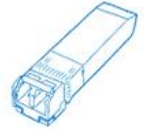

**Recommended Circuit:**

**[2.5Gb/s SFP Optical Transceiver without DDMI \(PTP883D2-3\)](#)**  
**[Hot Pluggable, Duplex LC, +3.3V, 1310nm, DFB-LD, Single-Mode](#)**

